

AIR FORCE T.O. 33A1-8-468-11
ARMY TM 11-6625-1711-15-1
NAVY NAVAIR 16-30APM245-2

T E C H N I C A L M A N U A L

OPERATION AND SERVICE/Organizational, GS
AND DEPOT MAINTENANCE MANUAL
WITH
ILLUSTRATED PARTS BREAKDOWN

SIMULATOR TEST SET
AN/APM-245A

HAZELTINE CORPORATION

F33657-71-C-0598

F41608-76-D-A068

This technical manual and the equipment covered herein is configured for inter-service use and maintainability by direction of the Department of Defense AIMS System Program Office (DOD-AIMS SPO). No changes shall be made to the equipment or the Technical Manual without the approval of the DOD AIMS SPO.

Published under authority of the Secretaries of the Air Force, Army, and Navy.

This copy is a reprint which includes current pages from Changes 1 through 3.

1 AUGUST 1973

T.O. 33A1-8-468-11
TM 11-6625-1711-15-1
NAVAIR 16-30APM245-2

CONFIGURATION CHART

T.O. ISSUE	ECPs	PRODUCTION EFFECTIVITY	TCTOs
1 August 1973	None	1 and up	None

TABLE OF CONTENTS

Section	Page	Section	Page
I	INTRODUCTION AND GENERAL INFORMATION	4-36.	Mode 4 Reply Procedure
	1-1		4-15
	1-1. Scope	4-37.	Disparity Pulse Procedure
	1-1		4-15
	1-3. Maintenance Forms and Records	4-38.	Marker Pulses Procedure
	1-1		4-15
	1-7. Purpose of Equipment . .	4-39.	Stopping Procedure
	1-1		4-15
	1-9. General Description . .	V	OPERATOR AND ORGANIZATIONAL PREVENTIVE MAINTENANCE
	1-11. Characteristics		5-1
	1-13. Equipment Supplied . . .		5-1. General
	1-15. Index of Equipment Publications		5-1
	1-1		5-3. Preventive Maintenance Checks and Services . .
II	SPECIAL TOOLS AND TEST EQUIPMENT		5-5. Cleaning
	2-1		5-7. Touch-Up Painting . . .
	2-1. General		5-1
	2-1	VI	MAINTENANCE INSTRUCTIONS
III	PREPARATION FOR USE AND SHIPMENT		6-1
	3-1	6-1.	General
	3-1. Scope		6-1. Test Equipment Required .
	3-1		6-1
	3-3. Unpacking		6-5. Operational Checkout . .
	3-1		6-6. General
	3-5. siting		6-7. Internal Trigger Check .
	3-1		6-8. External Trigger Check .
	3-7. Connections		6-9. Test Word Check
	3-1		6-10. Mode 4 Reply Check . .
	3-9. Pre-operational Checks		6-11. Inspection and Preventive Maintenance
	3-1		6-13. Troubleshooting
	3-11. Preparation for Shipment		6-15. Repair
	3-4		6-17. Test
	3-4		6-19. Calibration
	3-4		6-21. Power Supply Alignment .
	3-4		6-9
IV	OPERATION INSTRUCTIONS . .	VII	DEPOT OVERHAUL STANDARDS
	4-1		7-1
	4-1. Introduction		7-1. Applicability of Depot Inspection Standards . .
	4-1		7-3. Applicable References . .
	4-3. Theory of Operation . .		7-4. Repair Standards
	4-1		7-5. Technical Publications .
	4-4. General		7-6. Modification Work Orders
	4-1		7-7. Test Facilities Required
	4-5. Test Word		7-10. Internal Trigger Operation Tests
	4-7		7-12. External Trigger Operation Tests
	4-21. Auxiliary Pulse		7-4
	4-7		
	4-23. Marker Pulses		
	4-7		
	4-24. Mode 4 Reply		
	4-7		
	4-26. Disparity Pulse		
	4-8		
	4-29. Power Supply Circuits .		
	4-8		
	4-30. Operation Instructions		
	4-11		
	4-31. Controls and Indicators		
	4-11		
	4-32. Input and Output Connectors		
	4-11		
	4-33. Starting Procedure . . .		
	4-14		
	4-34. Test Word Procedure . .		
	4-14		
	4-35. Auxiliary Pulse Procedure		
	4-15		

TABLE OF CONTENTS (Cont)

Section	Page	Section	Page
7-14. Test Word Output Tests	7-4	Group Assembly Parts List	9-11
7-16. Mode 4 Reply Oper- ation Tests	7-6	Numerical Index	9-23
7-18. Mode 4 Connectors Resistance Tests.	7-9	Reference Desig- nation Index	9-26
VIII DIAGRAMS.	8-1	Appendix A REFERENCES	A-1
8-1. General	8-1	Appendix B MAINTENANCE ALLOCATION	B-1
IX ILLUSTRATED PARTS BREAKDOWN	9-1	Alphabetical Index	I-1
9-1. Introduction	9-1		

LIST OF ILLUSTRATIONS

Number	Title	Page	Number	Title	Page
1-1.	Simulator Test Set AN/APM-245A	vi	7-4.	Mode 4 Tests, Test Setup . . .	7-8
3-1.	Simulator Test Set, Outline Dimensional Drawing	3-2	8-1.	Simulator Test Set, Logic Circuits, Schematic Diagram	8-2
3-2.	Simulator Test Set, External Connections	3-3	8-2.	Simulator Test Set, Power Supply Circuits, Schematic Diagram	8-5
4-1.	Test Word, Auxiliary Pulse, Markers Generator Circuits, Logic Block Diagram	4-3	8-3.	Integrated Circuits, Logic Diagram Equivalents	8-6
4-2.	Mode 4 Reply and Disparity Pulse Generator Circuits, Logic Block Diagram	4-9	8-4.	Simulator Test Set, Wave - forms	8-8
4-3.	Simulator Test Set, Controls, Indicators, and Connectors. . .	4-13	9-1.	Simulator Test Set AN/APM-245A	9-9
6-1.	Logic Troubleshooting Flow Chart	6-5	9-2.	Simulator Test Set AN/APM-245A	9-10
7-1.	Internal Trigger Tests, Test Setup	7-3	9-3.	Test Set	9-12
7-2.	External Trigger vs. Internal Trigger Jitter Test, Test Setup.	7-5	9-4.	Test Set Front Panel	9-14
7-3.	Test Word Output Tests, Test Setups	7-7	9-5.	Logic Assembly	9-16
			9-6.	Power Supply Assembly	9-20
			9-7.	Power Cable Assembly	9-22
			9-8.	BNC Video Coax Cable Assembly	9-22

LIST OF TABLES

Number	Title	Page
1-1	Leading Particulars	1-2
1-2	Equipment Supplied	1-5
2-1	Special Tools and Test Equipment List	2-1
4-1	Simulator Test Set, Controls and Indicators	4-12
4-2	Simulator Test Set, Input and Output Connectors	4-14
5-1	Preventive Maintenance Checks and Services, Daily Schedule (Operator Maintenance Category)	5-2
5-2	Preventive Maintenance Checks and Services, Weekly Schedule (Operator Maintenance Category)	5-3
5-3	Preventive Maintenance Checks and Services, Monthly Schedule (Organizational Maintenance Category)	5-4
7-1	Test Facilities Required	7-1

WARNING

DANGEROUS VOLTAGES EXIST IN THIS
EQUIPMENT.

Be careful when working on or near the
115-volt ac line connection.

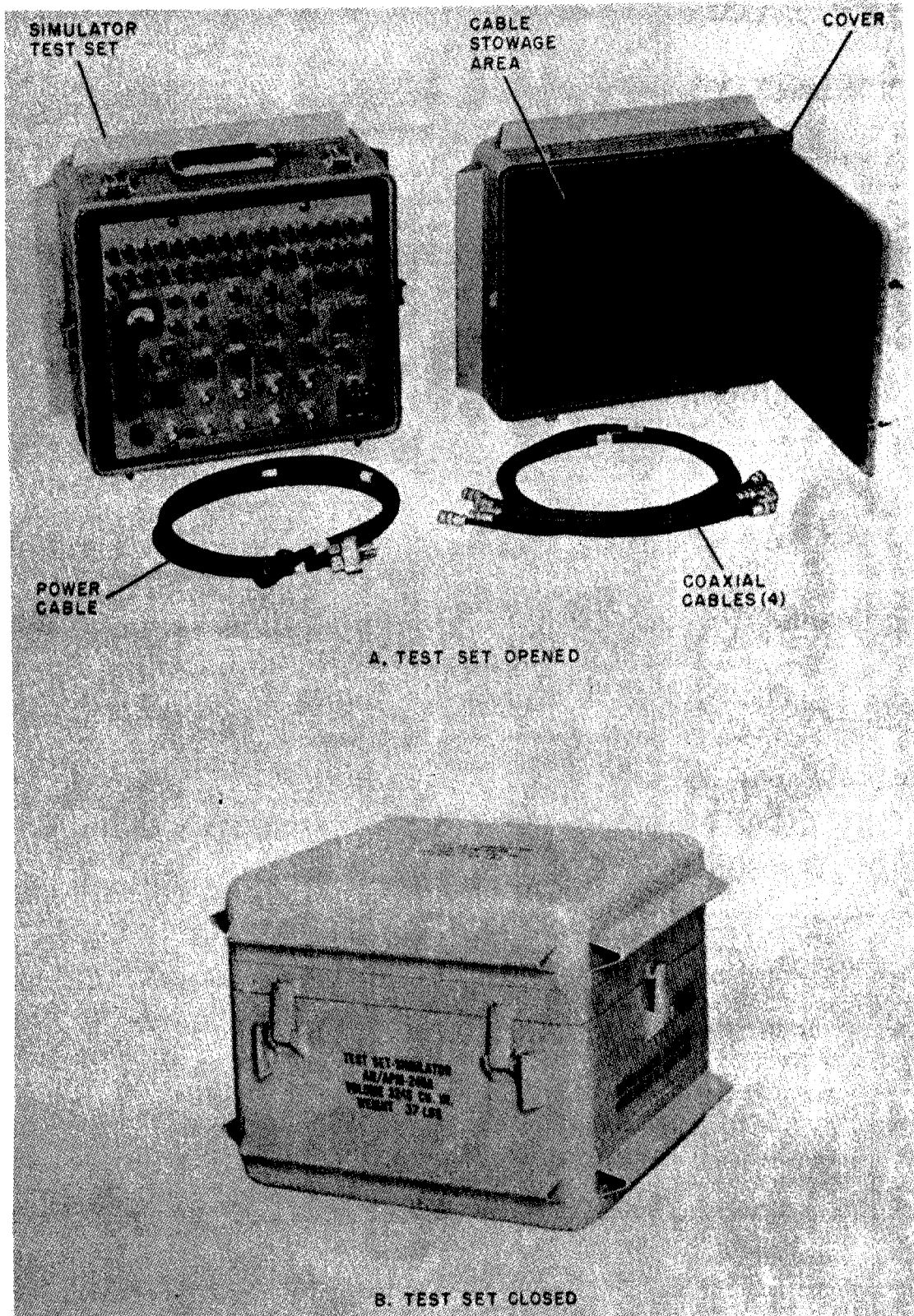

Figure 1-1. Simulator Test Set AN/APM-245A

SECTION I

INTRODUCTION AND GENERAL INFORMATION

1-1. SCOPE.

1-2. This manual contains general operation, operators and organizational maintenance, intermediate maintenance, and depot overhaul maintenance instructions for Simulator Test Set AN/APM-245A. (See figure 1-1.) Operating procedures are described in Section IV. Organizational, intermediate, and depot maintenance instructions are provided in Sections V, VI, and VII, respectively, and include instructions for troubleshooting, testing, and aligning the equipment. Also included in this manual are a description of the theory of operation (Section IV), a parts list (Section IX), and equipment schematics and test data (Section VIII).

NOTE

This technical manual and the equipment covered herein are configured for interservice use and maintainability by direction of the Department of Defense AIMS System Program Office (DOD AIMS SPO). No changes shall be made to the equipment or the technical manual without the approval of the DOD AIMS SPO.

1-3. MAINTENANCE FORMS AND RECORDS.

1-4. REPORTS OF MAINTENANCE AND UNSATISFACTORY EQUIPMENT. Department of the Army forms and Procedures used for equipment maintenance will be those prescribed in TM 38-750.

1-5. REPORT OF PACKAGING AND HANDLING DEFICIENCIES. Fill out and forward DD Form 6 (Report of Packaging and Handling Deficiencies) as prescribed in AR 700-58 (Army), NAVSUP Pub 378 (Navy), and AFR 71-4 (Air Force).

1-6. REPORTING OF ERRORS. The reporting of errors, omissions, and recommendations

for improving this publication by the individual user is encouraged. Reports should be submitted on DA Form 2028 (Recommended Changes to DA Publications) and forwarded direct to Commanding General, U.S. Army Electronics Command, Attn: AMSEL-MA-S, Fort Monmouth, N. J. 07703.

1-7. PURPOSE OF EQUIPMENT.

Simulator Test Set AN/APM-245A (hereafter referred to as the simulator test set) is a portable facility used for maintenance support of transponder and interrogator units. The simulator test set provides the mode 4 signals necessary for bench testing and adjusting these units.

1-9. GENERAL DESCRIPTION.

1-10. The simulator test set is contained in a portable aluminum carrying case. All controls, switches, connectors, and indicators are located on the front panel with coaxial cables, power cable, and accessories located under the cover.

1-11. CHARACTERISTICS.

1-12. The electrical and mechanical characteristics of the simulator test set are listed in table 1-1.

1-13. EQUIPMENT SUPPLIED.

1-14. The equipment supplied with the simulator test set are listed in table 1-2.

1-15. INDEX OF EQUIPMENT PUBLICATIONS.

1-16. Refer to the latest issue of DA Pam 310-4 (Army), NAVSUP 2002 Section VIII (Navy), or publications pertaining to the equipment.

1-17. Refer to DA Pam 310-7 (Army) to determine whether there are Modification Work Orders (MWO'S) pertaining to the equipment.

TABLE 1-1. LEADING PARTICULARS

Nomenclature:	Simulator Test Set AN/APM-245A
Weight:	37 lbs.
Overall dimensions:	
Height	12.88 inches
Width	16.62 inches
Length	15.25 inches
Input power requirements:	115 volts, 60 or 400 Hz, single-phase
Input signals:	
Mode 4 trigger:	
Amplitude	1.5 to 5.0 volts across an impedance of 82 to 100 ohms
Polarity	Positive
Pulse width	0.3 to 3.0 microseconds
Rise time	0.10 microsecond maximum
Fall time	1.0 microsecond maximum
Undesired signal	±0.5 volt peak
Rate	0 to 3,000 pulses per second
External trigger:	
Amplitude	4 to 40 volts across an impedance of 67.5 to 82.5 ohms
Polarity	Positive or negative
Pulse width	0.5 to 1.0 microsecond
Rise time	0.2 microsecond maximum
Fall time	0.5 microsecond maximum
Rate	10 to 10,000 pulses per second
Mode 4 video:	Terminated in a resistive load-of 82 to 100 ohms, 20 milliwatts maximum dissipation

TABLE 1-1. LEADING PARTICULARS (Cent)

Output signals:	
Test word:	
Amplitude	Adjustable from 5.0 to 35 volts across 67.5 to 82.5 ohms resistive
Polarity	Positive
Pulse width	0.4 to 0.6 microsecond
Rise time	0.1 microsecond maximum
Fall time	0.2 microsecond maximum
Number of pulses	Up to 37 (selectable)
Pulse spacing	Within ± 0.1 microsecond of even multiples of 1 microsecond from leading edge of first pulse
Rate	10 to 10,000 pulses per second
Auxiliary pulse:	
Amplitude (at TEST WORD connector)	Same as test word pulses
Amplitude (at AUX PULSE connector)	Adjustable from 5 to 35 volts across 67.5 to 82.5 ohms resistive
Polarity	Positive
Delay	From 0.7 microsecond before first bit of test word to 10 microseconds after first bit
Pulse width	0.4 to 0.6 microsecond
Rise time	0.1 microsecond maximum
Fall time	0.2 microsecond maximum
Rate	10 to 10,000 pulses per second
Disparity pulse:	
Amplitude	3 to 5 volts across 82 to 100 ohms resistive
Polarity	Positive
Pulse width	0.3 to 1.0 microsecond
Rise time	0.15 microsecond maximum

TABLE 1-1. LEADING PARTICULARS (Cont)

Disparity pulse: (cont)	
Fall time	0.5 microsecond maximum
Delay position 1	Continuously variable from 8 to 76 microseconds as measured from first bit in test word
Delay position 2	Continuously variable from 194 to 276 microseconds as measured from first bit in test word
Rate	same as mode 4 trigger
Mode 4 reply:	
Amplitude	Adjustable from 2 to 35 volts across 82 to 100 ohms resistive
Polarity	Positive
Pulse width	0.3 to 0.7 microsecond
Rise time	0.1 microsecond maximum
Fall time	0.25 microsecond maximum
Pulse train position	Adjustable from 200 to 276 microseconds as measured from first bit in test word
Rate	Same as mode 4 trigger
Pulse spacing	3 pulses spaced 1.6 to 2.0 microseconds between leading edges of consecutive pulses
Marker output:	
Amplitude	Adjustable from 0 to 10 volts across 459 to 561 ohms resistive
Pulse spacing	0.09 to 1.01 microseconds
Waveform	1-MHz square wave
Trigger output:	
Amplitude	6 to 10 volts across 75 ohms resistive
Polarity	Positive
Pulse width	0.3 microsecond minimum to 25 microseconds maximum
Rise time	0.2 microsecond maximum

TABLE 1-1. LEADING PARTICULARS (Cont)

Trigger output:	
Fall time	0.5 microsecond maximum
Rate	For internally selected, adjustable in ranges of 10 to 100 Hz, 100 to 1,000 Hz, and 1,000 to 10, 000 Hz. Externally selected range from 10 to 10,000 Hz.
Time jitter (externally selected)	1.1 microseconds maximum between external trigger and trigger output

TABLE 1-2. EQUIPMENT SUPPLIED

QUANTITY	DESCRIPTION	HAZELTINE PART NO.
1	Test Set, Simulator AN/APM-245A	121984-1
4	Cable assembly, radio frequency	117743
1	Cable assembly, power electrical	117740
1	Fuse cartridge (includes 1 spare)	FMO3-1/2A
1	Manual, technical, T.O. 33A1-8-468-11/ TM 11-6625-1711-15-1/NAVAIR 16-30APM245-2	IB-1966A

SECTION II

SPECIAL TOOLS AND TEST EQUIPMENT

2-1. GENERAL.

2-2. The special tools and test equipment list shown in table 2-1 is a compilation of all test facilities required to test, troubleshoot,

align, and calibrate the simulator test set. If any equipment listed in table 2-1 is not available, an equivalent equipment may be used instead. There are no special tools required in servicing the simulator test set.

TABLE 2-1. SPECIAL TOOLS AND TEST EQUIPMENT LIST

TOOL/EQUIPMENT NUMBER	NOMENCLATURE	USE AND APPLICATION
AN/UPM-15A	Pulse Generator	Provides mode 4 trigger input signal during mode 4 tests and is used in measuring internal vs. external jitter.
AN/USM-207A	Electronic Counter	Used in marker frequency and internal trigger measurement tests.
AN/USM-281A	Oscilloscope	Used in checking waveforms during testing and troubleshooting.
TS-352B	Multimeter	Used in making voltage checks during troubleshooting.
N/A	Resistive Termination, 75-ohm, 2-watt (3 required)	Provides load during testing and troubleshooting.
N/A	Resistive Termination, 91-ohm (2 required)	Provides load during testing and troubleshooting.
N/A	Resistive Termination, 510-ohm (1 required)	Provides load during testing and troubleshooting.
N/A	Resistive Termination, Carbon, 10-ohm, 2. 5-watt (1 required)	Provides load during testing of +5-volt power supply output after repair has been effected.
N/A	Resistive Termination, Carbon, 150-ohm, 20-watt (1 required)	Provides load during testing of +50-volt power supply output after repair has been effected.

SECTION III

PREPARATION FOR USE AND SHIPMENT

3-1. SCOPE.

3-2. This section contains procedures for unpacking, inspecting, and siting the simulator test set. In addition, information concerning power considerations and pre-operational checkout procedures are included.

3-3. UNPACKING.

3-4. No special instructions are required to remove the simulator test set from the shipping container other than the usual precautions for unpacking delicate electronic equipment. After the simulator test set is unpacked, visually inspect the equipment for broken switches or controls, possible cracked or broken PRF KHZ meter glass front, and for loose panel connectors. A check should be made for completeness of equipment, using the enclosed packing list and the information contained in table 1-2.

3-5. SITING.

3-6. The simulator test set is intended for use on a work bench, in conjunction with transponder and/or interrogator units to be tested and other associated test equipment. Space requirements can be determined from the leading particulars shown in table 1-1 and the outline dimensional drawing shown in figure 3-1. Arrange the simulator test set and other associated equipment to permit ease of access to controls and connectors. Because all the controls, connectors, and indicators are accessible from the front panel, no special clearance arrangements are required at the rear or sides of the equipment case.

3-7. CONNECTIONS.

WARNING

Exercise caution when working with the 115-volt power source. Serious injury or loss of life may result from contact with this voltage.

3-8. A list of input and output signal connectors on the front panel of the simulator test set is given in table 4-2. Figure 3-2 shows the external connections for the simulator test set. Refer to figure 4-3 for the locations of these connectors on the simulator test set.

3-9. PRE-OPERATIONAL CHECKS.

NOTE

Service personnel should be generally familiar with the locations and functions of all controls and indicators, as referenced in figure 4-3 and table 4-1, respectively, before attempting to perform the pre-operational checks.

3-10. Prior to operating the simulator test set with associated test equipment, perform the following pre-operational checks:

Check that the simulator test set is properly grounded.

b. Set the ON-OFF switch to the OFF position.

c. Set all 37 TEST WORD switches to the down (off) position,

d. Set the AUX PULSE ON-OFF switch to the OFF position.

e. Set the DISPARITY DL-1/OFF/DL-2 switch to the OFF position.

f. Rotate the DISPARITY DELAY control fully counterclockwise.

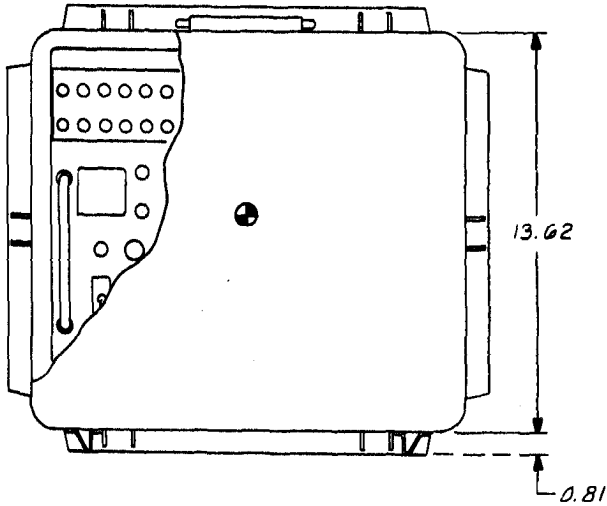

- NOTES:
1. UNLESS OTHERWISE SPECIFIED, ALL DIMENSIONS ARE IN INCHES AND ARE NOMINAL.
 2. ⊕ DENOTES CENTER OF GRAVITY.
 3. WEIGHT OF UNIT - 37 LBS.
 4. ESTIMATED POWER DISSIPATED WITHIN UNIT - 30 WATTS.

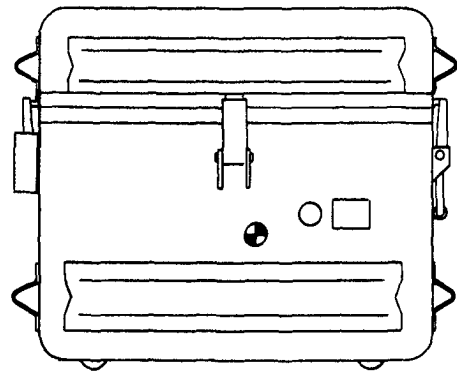
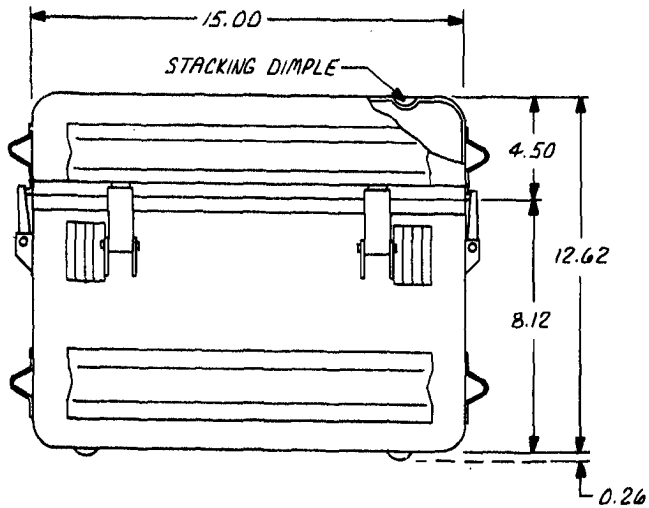

Figure 3-1. Simulator Test Set, Outline Dimensional Drawing

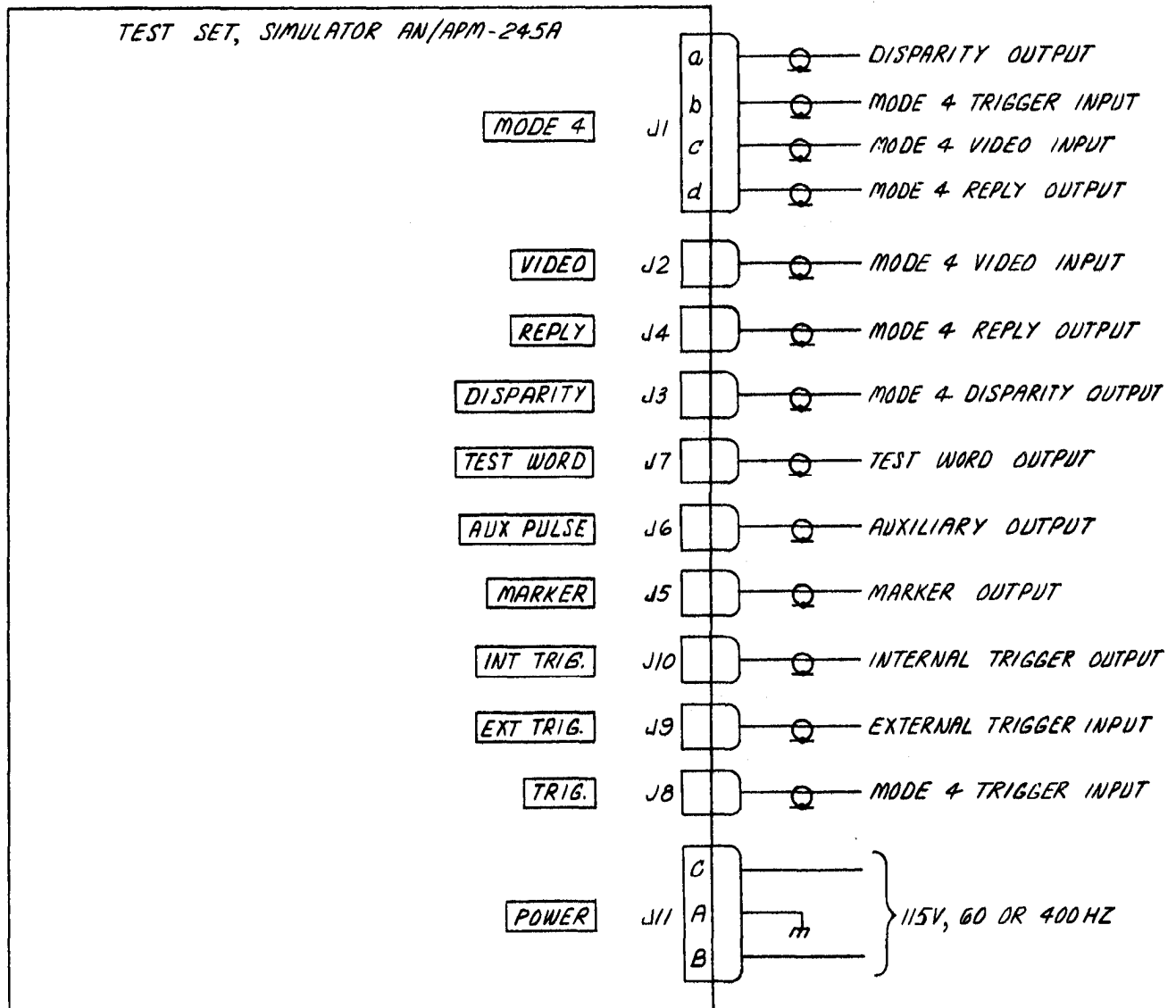

Figure 3-2. Simulator Test Set, External Connections

T.O. 33A1-8-468-11
TM 11-6625-1711-15-1
NAVAIR 16-30APM245-2

- g. Rotate the AUX PULSE AM control fully counterclockwise.
- h. Set the MODE 4 REPLY ON-OFF switch to the OFF position.
- i. Rotate the MODE 4 REPLY AM control fully counterclockwise,
- j. Rotate the MARKER AMPLITUDE control fully counterclockwise.
- k. Set the GO/OFF/NO-GO switch to the OFF position.
- l. Set the FUNCTION switch to the INT/EXT position.
- m. Set the PRF SEL switch to the INT-MED position.
- n. Rotate the TEST WORD AMPLITUDE control fully counterclockwise.
- o. Connect power cable W1 from 115-volt, 60- or 400-Hz power source to POWER connector on the simulator test set.

- p. Set the ON-OFF switch to the ON position. The POWER indicator should light, (If POWER indicator goes out, check for defective fuse.)
- r. Adjust INT PRF FREQ ADJ control and check that the PRF KHZ meter indication varies in accordance with the adjust of the control.
- s. Set the ON-OFF switch to the OFF position. The POWER indicator should go out.

3-11. PREPARATION FOR SHIPMENT.

3-12. There are no special instructions to follow in preparing the equipment for shipment. Place the cables and this technical manual behind the lid on the inside of the case cover and attach and lock the cover to the case. Place the complete set into its shipping container, surrounding the set with shock absorbent material. Secure the shipping container with metal banding straps.

SECTION IV

OPERATION INSTRUCTIONS

4-1. INTRODUCTION.

4-2. This section contains a description of the theory of operation of the simulator test set, a listing and a functional description of each control and indicator, and complete operation instructions. Basic circuit theory is not described; however, detailed operation of those circuits necessary to the understanding of the theory of operation at the logic block diagram level is included. (For complete schematic diagrams of the equipment, see figures 8-1 and 8-2; integrated circuit pin locations and equivalent schematic representations are shown in figure 8-3.)

4-3. THEORY OF OPERATION.

4-4. GENERAL. The simulator test set generates five video signals for use in the testing and alignment of mode 4 interrogator and transponder equipments. These signals are a 37 bit-selectable test word (used to simulate a mode 4 interrogation), an auxiliary pulse, a simulated mode 4 reply, a disparity pulse, and marker pulses. With the exception of the test word and marker pulses, these signals can be time-delayed over specific ranges, thereby simulating normal and abnormal operating conditions for the transponder or interrogator under test. The generation of these signals is described in the following paragraphs.

NOTE

Except for the front-panel selector switches, the amplitude, delay, and frequency adjustment potentiometers, and the PRF KHZ meter, the logic circuitry described in paragraphs 4-5 through 4-28 are located on printed-circuit board A1. To complete the reference designations mentioned in these paragraphs, prefix the symbol with A1.

4-5. TEST WORD. (See figure 4-1.) The test word consists of up to 37 bits (each bit individually selected by corresponding front-panel TEST WORD switches), which are

generated in series by the test word generator circuits (paragraph 4-6). The number of test words generated is determined by the test word program circuits (paragraph 4-11) at a repetition rate determined by the prf generator circuits (paragraph 4-16). Under normal operating conditions, the program circuits allow a continuous generation of test words. For the go and no-go modes of operation, the program circuits are factory-set for the generation of four and three test words, respectively, each time test set operation is initiated via the front-panel GO/NO-GO push-button switch. (The number of test words generated in either mode can be changed by reconnecting several jumper wires on logic board A1.)

4-6. Test Word Generator Circuits. These circuits consist of a six-stage binary counter (U15B, U15A, U22B, U28B, and U28A), strobe enable gates (U27A, U26B, U26A, and U26C), and five multiplexer circuits (U32 through U36). The input timing signal to the six-stage counter is derived from the 2-MHz crystal clock generator (Y1, U6A, U6B). The output frequency of this crystal oscillator is divided to 1 MHz by flip-flop U21A and the \bar{Q} output of U21A is further divided to 0.5 MHz by flip-flop U21B. (The 1-MHz Q output of U22A is used in generating the marker pulses (paragraph 4-23) and to trigger the auxiliary pulse and clock gate generator circuits (paragraphs 4-17 and 4-21 or 4-20, respectively).) The generation of a complete test word cycle is described in paragraphs 4-7 and 4-8.

4-7. A test word is generated only when clock gate (+) is high. (See figure 4-1, sheet 2.) This level occurs when the clock gate generator circuits are triggered by clock pulses at a selected prf. (See paragraph 4-20.) Before the test word cycle is initiated, all the flip-flops of the binary counter and the input trigger flip-flop (U21B) are placed in the reset state by the low-level clock gate (+), which also inhibits counter operation until a high-level clock gate (+) is produced. When this occurs, input trigger flip-flop U21B and all the flip-flops in the counter are enabled but remain in the reset state until the

first 0.5-MHz pulse is applied to the counter input. Because the \bar{Q} output of each flip-flop in the counter is used to trigger the succeeding stage, all the flip-flops are switched to the set state so that the counter counts down with each successive trigger input.

4-8. When all the flip-flops in the counter are in the set state, the most-significant bit outputs (D, E, F and the complementary bits) are decoded by the strobe enable gates to produce the strobe 1-7 input to the first multiplexer stage. The strobe 1-7 signal enables this stage so that the least-significant bit outputs of the counter (\bar{A} , \bar{B} , and \bar{C}), which are applied to the data select inputs of all the multiplexer stages, can sequentially scan the eight data inputs. Depending upon the TEST WORD switches selected, therefore, pulses are produced in series at the data output of the first multiplexer stage at the corresponding bit positions in the test word. (Because the first data input is grounded in this stage, there is no test word bit generated at the first count so that only selected bits from 1 through 7 are available.) After the data inputs have been scanned, the most-significant bit outputs of the counter cause the strobe enable gates to terminate strobe 1-7 and produce strobe 8-15, which enables the second multiplexer stage. The \bar{A} , \bar{B} , and \bar{C} outputs of the counter now scan the eight data inputs of the second multiplexer stage to produce the next series of selected test word bits (8 through 15) at the output. This process of multiplexer strobing and data input scanning continues until the 37 test word bit positions have been serially gated through OR gate U30. Once the 37 test word bits have been scanned, the next trigger input (the 38th pulse) to the counter causes the \bar{F} , D, \bar{C} , and \bar{B} inputs to AND gate U27B to be high, and the clock gate reset pulse output resets flip-flop U7C-U7D in the clock gate generator circuits. (See paragraph 4-20.) As a result, a low-level clock gate (+) is produced, which resets all the flip-flops in the counter and input trigger flip-flop U21B. Until the next high-level clock gate (+) is produced, the test word generator circuits remain quiescent.

4-9. The test word multiplex output from OR gate U30 is ANDed with the 0.5- and 1-MHz square waves at AND gate U29A resulting in 0.5-MHz test word pulses. These pulses are ORed with the auxiliary pulse (when selected by the AUXILIARY PULSE ON-OFF switch) at U26D. The test word bits are amplified by

transistors Q11 through Q14 before the signal is applied to the transponder under test. The TEST WORD AMPLITUDE control varies the supply voltage to the amplifier stages, thereby providing uniform amplitude control of all the test word bits.

4-10. Under normal operating conditions, the overload control circuit (Q15, U37B, R47, R48, CR13, and CR14) produces a high level which enables AND gates U29A and U29B so that the test word and auxiliary pulse (when selected) are applied to the output amplifier stages via U26D. When a short circuit or low output impedance occurs, diode CR14 is forward-biased, causing the resultant voltage drop across resistor R48 to back-bias diode CR13. Transistor Q15 is then cut off, the high level at the collector is inverted by U37B, and the low-level output inhibits the two AND gates, thereby disabling the test word and auxiliary pulse output.

4-11. Test Word Program Circuits. These circuits consist of the prf gate generator (U23B-U23A and U23D) and a four-stage binary counter (U19B, U19A, U3B, U3A). The prf gate generator enables the input clock trigger to the clock gate generator circuit and, in turn, the generation of the clock gate and test word. The binary counter, in conjunction with the GO/OFF/NO-GO switch and program selector gates (U12A, U12B, U17A, U17B, U17C, U18C, U18D, U16C), determine the length of the prf gate and, in turn, the number of test words to be generated.

4-12. The test word program circuits provide three modes of operation for the generation of test words: go, no-go and normal (free-running). In the go mode, the GO/OFF/NO-GO switch is set at the GO position, which disables no-go selector AND gate U17A. When the GO/NO-Go pushbutton switch is depressed, a momentary ground is placed at one input of flip-flop U23B-U23A. A high-level burst gate is produced at the output which enables AND gate U23C. At the same time, the complementary output of the flip-flop enables OR gate U23D, which produces a high-level prf gate. (See figure 4-1, sheet 3.) Both the burst gate and the prf gate remain high until the flip-flop is reset at the end of the go program. With AND gate U23C enabled by the burst gate, each clock gate (+) input to the AND gate (present during each test word cycle) is used as the input trigger

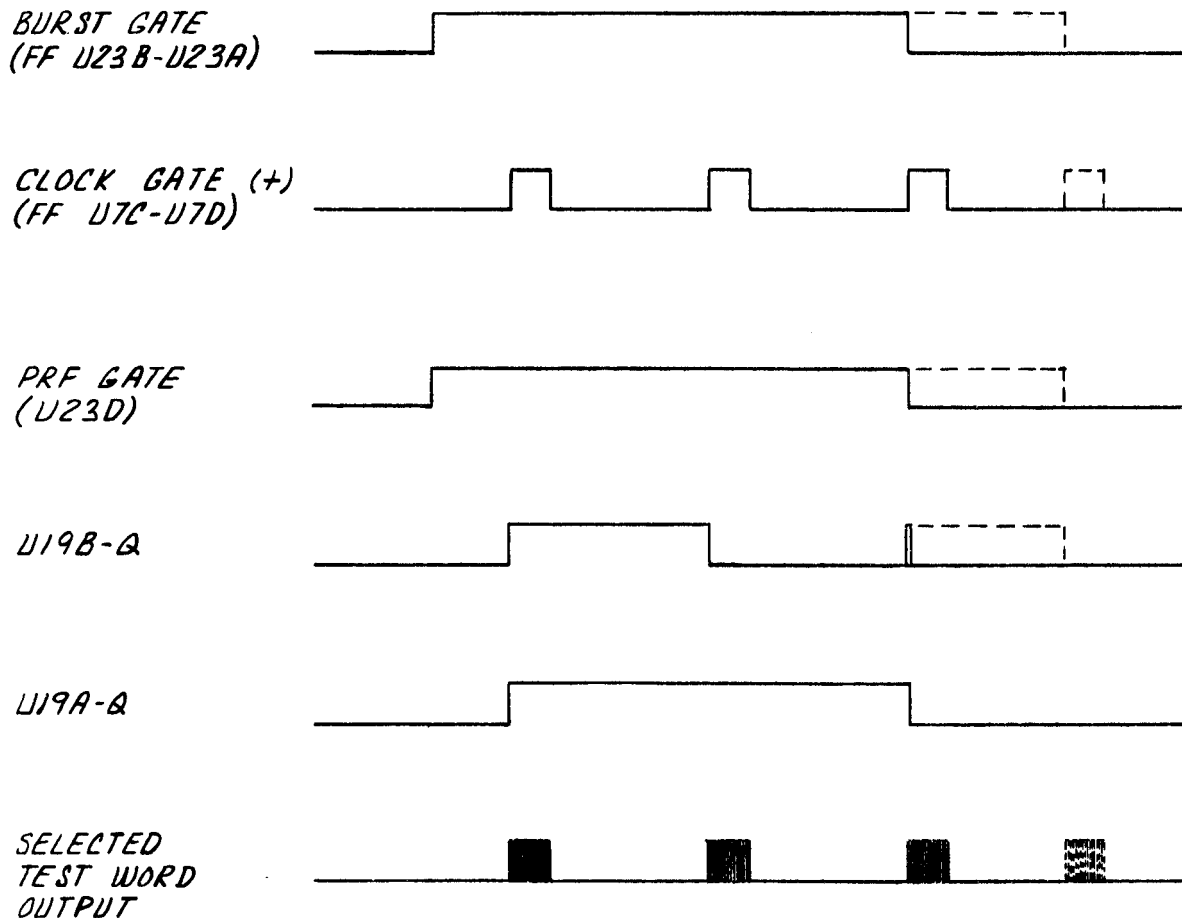

B. GO AND NO-GO TEST WORD PROGRAM CYCLES

NOTE:

*DASHED-LINE PULSES AND PULSE WIDTHS REPRESENT FACTORY-SELECTED GO MODE (4 TEST WORD CYCLES).
 SOLID-LINE PULSES AND PULSE WIDTHS REPRESENT NO-GO MODE (3 TEST WORD CYCLES).*

Figure 4-1. Test Word, Auxiliary Pulse, Markers Generator Circuits, Logic Block Diagram (Sheet 3 of 3)

to the four-stage binary counter. Therefore, the counter counts the number of test words being generated by the test set.

4-13. The flip-flop stages of the counter operate in the same manner as the counter flip-flop stages in the test word generator circuits. (See paragraph 4-7.) Because the counter counts down and the program jumper wires are factory-connected for four test words in the go mode, AND gate U12B is enabled when the high outputs from the counter are **D, C, \bar{B} , and \bar{A} .** (The jumper wires can be reconnected so that U12B is enabled after any number of test words have been generated. See figure 8-1, Note 3.) With the GO/OFF/NO-GO switch disabling no-go selector gate U17A, the decoded output of U12B is gated through U17B and OR gate U16C to reset flip-flop U23B-U23A, thereby terminating the burst gate. As a result, AND gate U23C is disabled and the counter is reset by the trailing edge of the burst gate. At the same time, the resetting of this flip-flop causes the prf gate output of OR gate U23D to be terminated, which disables the clock gate and auxiliary pulse generator circuits and, in turn, inhibits the generation of further test word cycles.

4-14. In the no-go mode, the GO/OFF/NO-GO switch is set at the NO-GO position, which disables go selector gate U17B and enables no-go selector gate U17A. Therefore, when the D, C, B and A outputs of the counter are high, AND gate U12A is enabled, and the output is gated through U17A and OR gate U16C to reset flip-flop U23B-U23A. In this manner, the burst gate and prf gate are terminated at the start of the third test word cycle. (The no-go mode can also be changed so that U12A is enabled after any number of test word cycles by reconnecting the program jumper wires. See figure 8-1, Note 3.)

4-15. In the normal (free-running) mode, the GO/OFF/NO-GO switch is set at the OFF position. With two high-level inputs present at the input to OR gate U17C, a low-level output is produced which causes OR gate U23D to produce the high-level prf gate. The prf gate remains high as long as the switch is set at the OFF position. Therefore, AND gate U16B in the prf generator circuits remains enabled and clock gates are repeatedly generated, then terminated at the end of the test word cycle, and generated again for the next test word cycle. The GO/NO-GO pushbutton switch is not

used in this mode and the binary counter and associated program selector gates remain disabled.

4-16. Prf Generator Circuits. These circuits consisting of an internal prf generator (Q2, Q1), an external trigger generator (Q3), and associated gating circuits (U6, U7, U8, and U16B), generate the prf triggers which determine the test word cycle frequency. The signal source for the prf generator circuits is either an external trigger or an internally generated prf trigger. Selection of the signal source is provided by the PRF SELECT switch. When the switch is set at the INT L position, an RC time constant for unijunction transistor Q2 is selected that causes the transistor to oscillate at a prf ranging from approximately 10 to 100 Hz. At the INT MED position, the RC time constant selected results in a prf range from approximately 100 to 1000 Hz, and at the INT H position, the range is from approximately 1 to 10 KHz. The desired prf within each of these ranges is obtained by adjusting the INT PRF FREQ ADJ potentiometer.

4-17. The internally generated prf trigger is gated through AND gate U7B and OR gate U8B, and is applied to the meter scale circuits (paragraph 4-19) and AND gate U16B. With U16B enabled by the prf gate from the test word program generator circuits (paragraph 4-12), the prf trigger gates through clock pulses at the selected prf. As a result, the clock gate (and, in turn, the test word generator circuits) and auxiliary pulse generator circuits are triggered at the same prf.

4-18. When the PRF SELECT switch is set at the EXT position, AND gate U7B is disabled, thereby inhibiting the internal prf generator output. In addition, a high output from inverter U6C is produced which enables AND gate U7A, thereby enabling the external trigger input. The external trigger can be positive or negative and can be within a prf range of 10 to 10,000 Hz. If the external trigger is positive, diode CR2 is back-biased while diode CR3 is forward-biased so that the signal is applied to external trigger inverter Q3. If the external trigger is negative, diode CR2 is forward-biased and diode CR3 is back-biased, and inverter Q3 is bypassed. The functional OR provides the input to inverter U24F from both the negative-going pulse output of Q3 and the negative-going external triggers passed by diode CR2. The resultant positive-going

pulses at the output of inverter U6D is then gated through AND gate U7A and OR gate U8B for use as the prf trigger.

4-19. The meter scale circuits (U25, U18A, U8A, U8C, U8D), in conjunction with the METER SCALE switch, provide a signal input to the PRF KHZ meter with a pulse width that corresponds to the meter scale selected. The meter provides an indication of the selected prf and is used when adjusting the INT PRF FREQ ADJ potentiometer. (See paragraph 4-16.) When the METER SCALE switch is held in the XI position for accurate readings up to 1 KHz, the RC time constant of capacitor C26 and resistors R56 and R57 causes a 250-microsecond output pulse width from single-shot U25. For prf readings above 1 KHz, the METER SCALE switch is released to the normal X10 position. Resistor R56 is shorted to +5 volts by the switch and the resultant change in the RC time constant for single-shot U25 causes an output pulse width of 25 microseconds; one-tenth the pulse width when the METER SCALE switch is at the XI position. With the FUNCTION switch set at the INT/EXT position, AND gate U8C is enabled and, because of the low-level output of inverter U18A, AND gate U8A is disabled. Therefore, the prf trigger from OR gate U8B is gated through U8C and OR gate U8D to the input of the single-shot. When the FUNCTION switch is set at the M4 TRIG position, U8C is disabled and the high-level output of U18A enables U8A so that the single-shot is triggered by a mode 4 gate generated by the mode 4 reply generator circuits. (See paragraph 4-24.)

4-20. Clock Gate Generator Circuit. Clock gate generator flip-flop U7C-U7D produces a high-level clock gate (+) when a clock pulse output from AND gate U16B in the prf generator circuits (paragraph 4-17) triggers auxiliary pulse generator single-shot U31. The flip-flop remains in this state until the end of the test word cycle. At this time, the clock gate reset pulse, produced by AND gate U27B in the test word generator circuits (paragraph 4-8), resets the flip-flop thereby terminating the high-level clock gate (+) output. Clock gate (-) is also amplified by Q9 and Q10 to provide test set sync to the equipment under test via the INT TRIG jack.

4-21. AUXILIARY PULSE. (See figure 4-1.) The auxiliary pulse position can be varied with respect to the first bit position in the test word

from 0.7 microsecond before to 10 microseconds after (approximately the fifth bit position). (See figure 4-1, sheet 2.) Auxiliary pulse delay single-shot U31 is triggered by the clock pulse output of AND gate U16B in the prf generator circuits (paragraph 4-17) at a rate determined by the prf trigger frequency. The pulse width at the output of U31 varies from 2 to 18 microseconds, depending upon the setting of the AUX PULSE DELAY potentiometer. The pulse width selected determines the amount of delay of the auxiliary pulse.

4-22. The trailing edge of the output pulse of single-shot U31 triggers auxiliary pulse single-shot U20, which produces a 0.5-microsecond pulse. The \bar{Y} output is amplified and inverted by transistors Q4 and Q5 before it is applied to the corresponding simulator test set output jack. The supply voltage to these stages is controlled by the AUX PULSE AM potentiometer. The Y output is applied to AND gate U29B in the test word generator circuits (paragraph 4-9), which is enabled when the AUX PULSE ON-OFF switch is set to the ON position. As a result, the auxiliary pulse is applied to the simulator test set TEST WORD output jack in conjunction with the generated test word. AND gate U29B is disabled, however, when a low output impedance or short circuit is detected by the overload circuit. (See paragraph 4-10.)

4-23. MARKER PULSES. (See figure 4-1, sheet 1.) Marker pulses are 1-MHz clock pulses that are produced at the Q output of flip-flop U21A in the clock generator circuits (paragraph 4-6). These pulses are amplified by transistors Q6, Q7, and Q8. The gain of these stages is controlled by the MARKER AMPLITUDE potentiometer.

4-24. MODE 4 REPLY. (See figure 4-2.) The mode 4 reply consists of three pulses spaced 1.8 ± 0.2 microseconds between leading edges of consecutive pulses. A simulated mode 4 reply is generated by the simulator test set when the MODE 4 ON-OFF switch is at the ON position and a mode 4 trigger is received. The trigger sets flip-flops U1A-U1B and U1C-U1D so that a high-level enable gate for AND gate U2B and a high-level mode 4 gate are generated, respectively. (The mode 4 gate is used in the meter scale circuits (paragraph 4-19) as the input signal when the FUNCTION switch is set at the M4 TRIG position.) The three triggers used in generating the three mode 4 reply

pulses are produced by single-shots U9, U10, and U11. Single-shot U9 is triggered by the trailing edge of the clock gate (-). The output pulse width, variable from approximately 100 to 250 microseconds, determines the amount of delay for the generation of the simulated mode 4 reply. (See figure 4-2, sheet 2.) This delay is varied by the setting of the MODE 4 REPLY DELAY potentiometer. The trailing edge of the U9 output pulse triggers single-shot U10, which produces a 1.8-microsecond output pulse. The trailing edge of this pulse, in turn, triggers single-shot U11, which also produces a 1.8-microsecond pulse. The three pulses appear at the output of OR gate U16A in series. The high-level enable gate from flip-flop U1C-U1D enables AND gate U2B so that each of the three pulses is gated through to trigger single-shot U5. Because this circuit produces a 0.5-microsecond pulse output for each of the three input triggers, the required mode 4 reply pulse width and pulse spacing are simulated. The mode 4 reply is then inverted by Q17 and amplified by emitter follower Q18 before the signal is applied to the output jack. The gain of the amplifier is controlled by the MODE 4 REPLY AM potentiometer.

4-25. Flip-flops U1A-U1B and U1C-U1D are used to enable the mode 4 reply (and mode 4 disparity) circuits when a mode 4 trigger is received and to inhibit the output when the input mode 4 triggers cease. The leading edge of the third trigger pulse (\bar{Y} output of U11) resets flip-flop U1A-U1B, which enables AND gate U2A. However, because the output of U10 is low, the output of U2A remains high, and flip-flop U1C-U1D remains in the set state. If another mode 4 trigger is received during the next prp, flip-flop U1A-U1B is again triggered to the set state and AND gate U2A is inhibited. If there is no mode 4 trigger input (figure 4-2, sheet 2, third prp), however, flip-flop U1A-U1B is triggered to the reset state and AND gate U2A is enabled again. The clock gate (-) input to single-shot U9 triggers the generation of the mode 4 reply triggers except that the trailing edge of the second pulse (Y output of single-shot U10) is gated through AND gate U2A. The low-level output of U2A resets flip-flop U1C-U1D, thereby removing the enable gate from AND gate U2B. As a result, the mode 4 reply and mode 4 disparity outputs are inhibited.

4-26. DISPARITY PULSE. (See figure 4-2.) A disparity pulse is generated when the DISPARITY DL-1/OFF/DL-2 switch is set to

either the DL-1 or DL-2 position and a mode 4 trigger is received. The mode 4 trigger activates the mode 4 reply generator circuits and an enable gate from flip-flop U1C-U1D enables AND gate U2C. The disparity pulse generator circuits (U13, U14, U4, U2C, U24E-Q19) produce a disparity pulse that can be delayed with respect to the first pulse in the test word from 8 to 80 microseconds when the switch is set at the DL-1 position, and delayed from 194 to 276 microseconds when the switch is set at the DL-2 position.

4-27. With the switch in the DL-1 position, single-shot U13 is enabled. A clock gate (-) triggers U13 and the trailing edge of the output pulse, in turn, triggers single-shot U14. Depending upon the setting of the DISPARITY DELAY potentiometer, the output pulse width of U13 can be varied from approximately 8 to 80 microseconds. The 0.7-microsecond disparity pulse output of U14, therefore, is delayed 8 to 80 microseconds from the input clock gate (-). With AND gate U2C enabled, the 0.7-microsecond output pulse of U14 is gated through the AND gate and inverted and amplified by U24E-Q19 before the signal is applied to the output jack.

4-28. With the switch in the DL-2 position, single-shot U4 is enabled. The clock gate (-) input triggers U4 on the trailing edge of the input signal and the trailing edge of the output pulse, in turn, triggers single-shot U14. As a result, the 0.7-microsecond output pulse from U14 is delayed 100 to 225 microseconds from the trailing edge of the input clock gate (-), depending upon the setting of the DISPARITY DELAY potentiometer. The resultant delay, therefore, totals from 194 to 276 microseconds from the first pulse in the test word.

4-29. POWER SUPPLY CIRCUITS. The simulator test set is powered by 115 volts ac, which is applied to power transformer T1. The outputs across the two secondary windings are applied to power supply board A2. This board contains the rectifier and regulator circuits which produce +50 and +5 volts dc to the front-panel potentiometers and the logic circuitry on logic board A1, respectively. An overvoltage protection circuit on power supply board A2 prevents damage to the integrated circuits by clamping the +5-volt output to ground when the regulator circuit fails.

4-30. OPERATION INSTRUCTIONS.

4-31. CONTROLS AND INDICATORS. The name, reference designation, and function of each control and indicator on the front panel of the simulator test set are given in table 4-1. The se controls and indicators are shown in figure 4-3 and are keyed by index number to the corresponding listing in the table.

4-32. INPUT AND OUTPUT CONNECTORS.

The name, reference designation, and function of each connector on the front panel of the simulator test set are given in table 4-2.

These connectors are shown in figure 4-3 and are keyed by index number to the corresponding listing in the table.

TABLE 4-1. SIMULATOR TEST SET, CONTROLS AND FUNCTIONS

CONTROL OR INDICATOR	DESIGNATION	INDEX NO. (FIG. 4-3)	FUNCTION
TEST WORD switches 1 through 37	S 1 through S37	1	Selects each of 37 possible corresponding test word bit positions.
PRF KHZ meter	M1	28	Indicates pulse repetition rate of trigger source selected by FUNCTION switch with multiplying factor selected by SCALE switch.
FUNCTION switch	S38	29	Selects either an internally generated or external trigger (INT/EXT), or mode 4 trigger (M4 TRIG) for PRF KHZ meter measurement.
SCALE switch	S39	27	Selects multiplying factor, X1 or X10, to be applied to indication on PRF KHZ meter.
GO/NO-Go pushbutton	S43	30	Initiates test word generation in either go or no-go modes as selected by GO/OFF/NO-GO switch.
GO/OFF/NO-GO switch	S44	26	Selects number of factory-set test word gene ration cycles: NO-GO (3 test words), GO (4 test words), OFF (continuous).
DISPARITY DL-1/OFF/ DL-2 switch	S42	31	Enables disparity pulse gene ration in either of two ranges of delay; 8-80 μ sec (DL-1) and 194-276 μ sec (DL-2).
DISPARITY DELAY potentiometer	R6	23	Controls amount of delay of disparity pulse over DL-1(8-80 μ sec) and DL-2 (194-276 μ sec) ranges.
MODE 4 REPLY DELAY potentiometer	R2	9	Controls amount of delay of mode 4 reply from 200 to 276 μ sec from test word first pulse.

TABLE 4-1. SIMULATOR TEST SET, CONTROLS AND INDICATORS (Cont)

CONTROL OR INDICATOR	DESIGNATION	INDEX NO. (FIG. 4-3)	FUNCTION
MODE 4 REPLY ON-OFF switch	S40	3	Enables mode 4 reply generator circuits.
MODE 4 REPLY AM potentiometer	R1	6	Adjusts amplitude of mode 4 reply pulses.
AUX PULSE ON-OFF switch	S41	2	Enables addition of auxiliary pulse to test word output.
AUX PULSE AM potentiometer	R4	5	Adjusts amplitude of auxiliary pulse.
AUX PULSE DELAY potentiometer	R5	7	Adjusts amount of auxiliary pulse delay from 0.7 μ sec before first bit position in test word to 10 μ sec after first bit.
PRF SEL switch	S45	4	Selects test word cycle prf trigger source as follows: a. EXT: external source ranging from 10 to 10,000 Hz. b. INT-L: internally generated trigger ranging from 10 to 100 Hz. c. INT-MED: internally generated trigger ranging from 100 to 1,000 Hz. d. INT-H: internally generated trigger ranging from 1,000 to 10,000 Hz.
ON-OFF switch	S46	25	Control application of 115 volts ac, 60- or 400-Hz primary power to simulator test set.
POWER indicator	DS1	24	Indicates when primary power is applied to simulator test set.
TEST WORD AMPLITUDE potentiometer	R13	22	Adjusts amplitude of test word bits.
MARKER AMPLITUDE potentiometer	R12	20	Adjusts amplitude of marker pulses.
INT PRF FREQ AIM potentiometer	R9	8	Adjusts pulse repetition rate of internally generated prf triggers when PRF SEL switch is at any INT position.

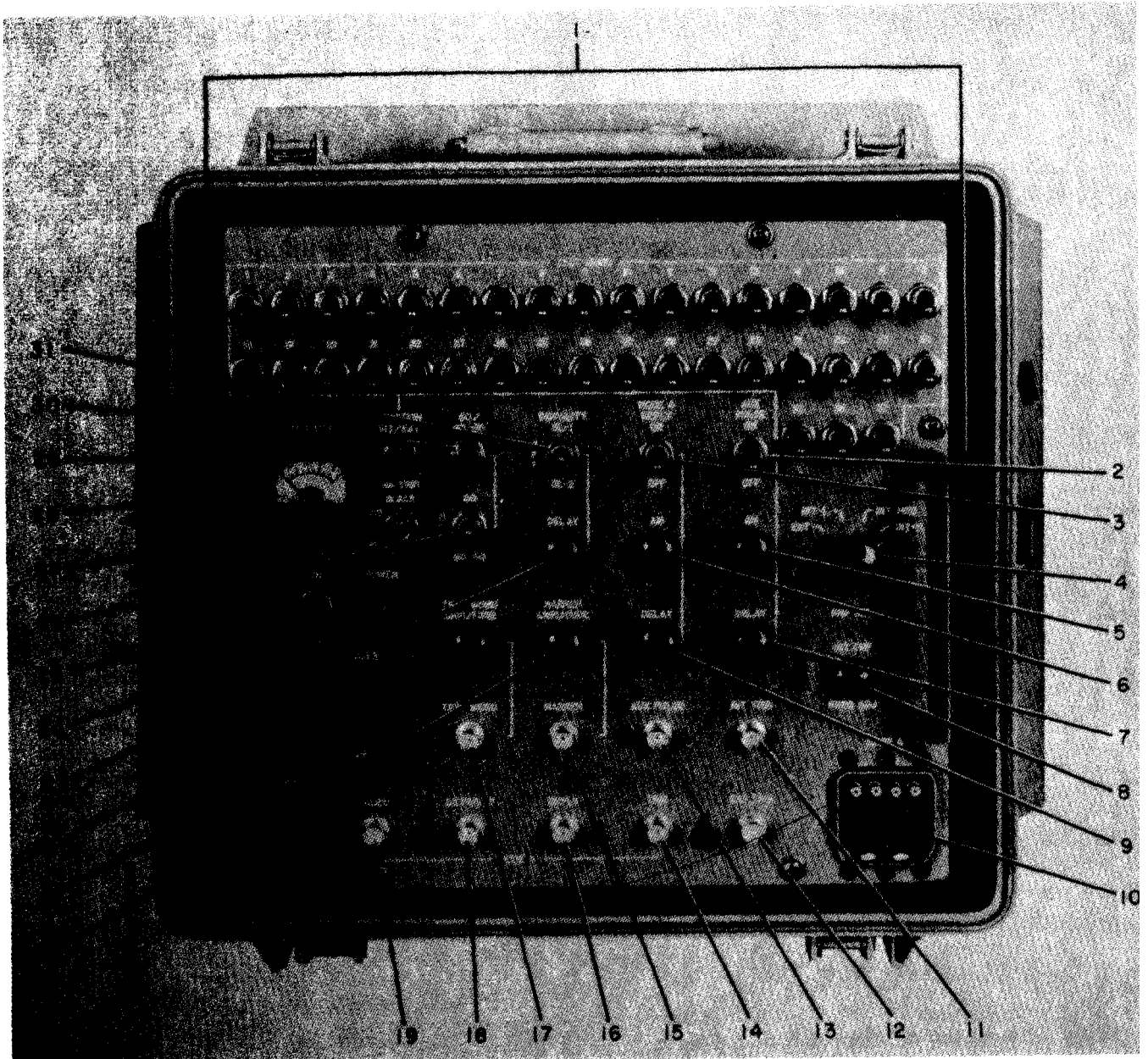

Figure 4-3. Simulator Test Set, Controls, Indicators, and Connectors

TABLE 4-2. SIMULATOR TEST SET, INPUT AND OUTPUT CONNECTORS

CONNECTOR	REFERENCE DESIGNATION	INDEX NO. (FIG. 4-3)	FUNCTION
TEST WORD	J7	17	Test word (and auxiliary pulse, when selected) output.
MARKER	J5	15	Marker pulses output.
AUX PULSE	J6	13	Auxiliary pulse output.
INT TRIG	J10	11	Clock gate (-) output used to trigger transponder or interrogator under test.
MODE 4 DISPARITY	J3	18	Disparity pulse output.
MODE 4 REPLY	J4	16	Mode 4 reply output,
EXT TRIG	J9	12	External trigger input which, when selected, determines simulator test set prf.
MODE 4 TRIG	J8	14	Mode 4 trigger input which is used to enable mode 4 reply and disparity pulse generation.
POWER	J11	21	115 volts ac primary power input.
MODE 4 VIDEO	J2	19	Provides load for input video signals,
MODE 4	J1	10	Four- pin connector for mode 4 reply and disparity pulse outputs and mode 4 trigger and video inputs.

4-33. STARTING PROCEDURE. To start the simulator test set, proceed as follows:

CAUTION

To avoid damage to the equipment under test, rotate the MODE 4 REPLY AM control to fully counter clockwise.

a. Connect the power cable to the POWER connector and to a primary 115-volt, 60- or 400-Hz power source. (See paragraph 3-7.)

b. Set the ON-OFF switch to the ON position and check that the POWER indicator is lighted.

4-34. TEST WORD PROCEDURE. To obtain a test word output at the TEST WORD connector, proceed as follows:

a. Select either external or internally generated prf triggers as follows:

(1) For external triggers, connect an external trigger source to the EXT TRIG connector and set the PRF SEL switch to the EXT position. Set the FUNCTION switch to the INT/EXT position.

(2) For internal triggers, set the PRF SEL switch to either the INT-L, INT-MED, or INT-H position (10- 100 Hz, 100-1,000 Hz,

or 1,000-10,000 Hz, respectively). Set the FUNCTION switch to the INT/EXT position and either leave the SCALE switch at the X10 position (for INT-H) or hold the switch in the X1 position (for INT-L or INT-MED). Adjust the INT PRF FREQ ADJ control for the desired repetition rate as indicated on the PRF KHZ meter.

b. Set those TEST WORD switches which correspond to the desired test word bit positions to the on position.

c. Set the GO/OFF/NO-Go switch to the OFF position. Using an oscilloscope at the TEST WORD connector, adjust the TEST WORD AMPLITUDE control for a pulse amplitude between 5 and 35 volts.

d. Set the GO/OFF/NO-GO switch to the desired mode of operation. For the GO or NO-GO positions, momentarily depress the GO/NO-GO pushbutton to initiate test word generation.

4-35. AUXILIARY PULSE PROCEDURE. To obtain an auxiliary pulse output at the AUX PULSE and/or TEST WORD connectors, proceed as follows:

a. Perform steps a., b., and c of paragraph 4-34.

b. Set the AUX PULSE ON-OFF switch to the ON position.

c. Using an oscilloscope at the TEST WORD connector, adjust the AUX PULSE DELAY control for the desired amount of delay (0.7 microsecond before the first test word bit to 10 microseconds after the first bit).

d. Connect the oscilloscope to the AUX PULSE connector and adjust the AUX PULSE AM control for a pulse amplitude between 5 and 35 Volts.

e. If the auxiliary pulse output is desired only at the AUX PULSE connector, set the AUX PULSE ON-OFF switch to the OFF position, and use a 75-ohm termination,

4-36. MODE 4 REPLY PROCEDURE. To obtain a mode 4 reply output at the MODE 4 and MODE 4 REPLY output connectors, proceed as follows:

a. Connect a mode 4 trigger source to the MODE 4 TRIG connector using a 91-ohm termination.

b. Set the MODE 4 REPLY ON-OFF switch to the ON position. Set the FUNCTION switch to the M4 TRIG position if it is desired to check the repetition rate of the mode 4 trigger. (In this case, leave the SCALE switch in the X10 position and, if the reading on the PRF KHZ meter is below 1, 000 Hz, hold the switch in the X1 position for a more accurate indication.)

Perform steps a. and b. of paragraph 4-34. and set the GO/OFF/NO-GO switch to the OFF position.

d. Connect the oscilloscope channel A (or B) to the TEST WORD connector and channel B (or A) to the MODE 4 REPLY connector. Adjust the MODE 4 REPLY DELAY control for the desired amount of delay with respect to the first pulse in the test word.

e. Adjust MODE 4 REPLY AM control for a pulse amplitude between 2 and 35 volts.

4-37. DISPARITY PULSE PROCEDURE . To obtain a disparity pulse output at the MODE 4 DISPARITY connector or the MODE 4 connector, proceed as follows:

Perform steps a., b., and c of paragraph 4-36.

b. Set the DISPARITY DL-1/OFF/DL-2 switch to either the DL-1 or DL-2 position.

Connect the oscilloscope channel A (or B) to the TEST WORD connector and channel B (or A) to the MODE 4 DISPARITY connector. Adjust the DISPARITY DELAY control for the desired amount of delay with respect to the first pulse in the test word.

4-38. MARKER PULSES PROCEDURE. To adjust the amplitude of the marker output pulses at the MARKER connector, adjust the MARKER AMPLITUDE control (using the oscilloscope connected at the MARKER connector and 510-ohm termination) for a pulse amplitude between 0 and 10 volts.

4-39. STOPPING PROCEDURE. To stop the operation of the simulator test set, proceed as follows:

T.O. 33A1-8-468-11
TM 11-6625-1711-15-1
NAVAIR 16-30APM245-2

a. If an external trigger source was used, disconnect the source from the EXT TRIG connector, but leave the PRF SEL switch at the EXT position. If an internally generated trigger source was used, set the PRF SEL switch to the EXT position.

b. Set the GO/OFF/NO-Go switch to either the GO or NO-GO position.

c. Set the MODE 4 REPLY ON-OFF switch to the OFF position. Set the DISPARITY DL-1/OFF/DL-2 switch to the OFF position.

d. Turn the MARKER AMPLITUDE control to the fully counterclockwise position.

e. If the simulator test set is to be completely shut down, set the ON-OFF switch to the OFF position. Note that the POWER indicator goes out.

SECTION V

OPERATOR AND ORGANIZATIONAL PREVENTIVE MAINTENANCE

5-1. GENERAL.

5-2. This section contains operator and organizational preventive maintenance procedures for the simulator test set. These procedures should be performed to prevent the occurrence of malfunctions, to reduce downtime, and to ensure equipment serviceability.

5-3. PREVENTIVE MAINTENANCE CHECKS AND SERVICES.

5-4. The preventive maintenance checks and services charts (tables 5-1, 5-2, and 5-3) outline the functions to be performed by the operator and organizational maintenance personnel at daily, weekly, and monthly intervals. These checks and services are to be followed to maintain U.S. Army electronic equipment in good physical and operating conditions. To assist operator and organizational maintenance personnel, the charts indicate what to check, how to perform the check, what the normal condition is, and for the operator, when (during operation) to perform the check. The Paragraph Reference column lists the paragraphs or illustrations which contain either the reference data, parts location, or detailed procedures. If the defect cannot be remedied by performing the corrective action indicated, higher echelon maintenance or repair is required.

5-5. CLEANING.

5-6. Inspect the exterior surfaces of the test set. These surfaces should be clean, free of dust, dirt, grease, and fungus. If required, clean the exterior surfaces as follows:

a. Remove dust and loose dirt with a clean, soft cloth .

WARNING

The cleaning compound used in step b, below, is flammable and the fumes toxic. Provide adequate ventilation when using this compound and do not use near a flame.

b. Remove grease, fungus, and ground-in dirt from the case, using a clean, lintless cloth dampened (but not wet) with cleaning compound, Federal Stock No. 7930-395-9542 (or equivalent).

c. Remove dust or dirt from connectors using a brush.

CAUTION

Do not press on the PRF KHZ meter glass when cleaning.

d. Clean the front panel, meter glass, and control knobs with a clean, soft cloth. If dirt is difficult to remove, dampen the cloth with water and, if necessary, use mild soap.

5-7. TOUCH-UP PAINTING.

5-8. Remove rust and corrosion from metal surfaces by lightly sanding the surfaces with fine sandpaper. Brush two thin coats of paint on the bare metal to protect the surface from further corrosion. Refer to the applicable cleaning and refinishing practices specified in TB SIG 364.

**TABLE 5-1. PREVENTIVE MAINTENANCE CHECKS AND SERVICES,
 DAILY SCHELDULE (OPERATOR MAINTENANCE CATEGORY)**

INTERVAL AND SEQUENCE NO.			ITEM TO BE INSPECTED	PROCEDURE	PARAGRAPH REFERENCE
BE FORE OPERATION	DURING OPERATION	AFTER OPERATION			
1	---	---	Complete equipment	Check that all items supplied are present.	Table 1-2
2	---	---	Connectors	Check tightness of all connectors.	Figure 4-3
3	---	---	PRF KHZ meter glass	Check PRF KHZ meter glass for cracks.	Figure 4-3
---	4	---	Controls and indicators	Observe mechanical action of each knob, dial, and switch for smoothness of operation and no excessive looseness. Check PRF KHZ meter for sticking or bent pointer.	Figure 4-3, paragraphs 4-33 through 4-39.
---	5	---	ON-OFF switch	Set to ON. Observe that POWER indicator lights.	Figure 4-3
---	6	---	INT PRF FREQ ADJ control	FUNCTION: INT/EXT PRF SELECT: INT-L, -MED, or -H Vary control and observe that PRF KHZ pulse repetition rate indication varies.	Figure 4-3
---	---	7	ON-OFF switch	Set to OFF. Observe that POWER indicator is extinguished.	Figure 4-3

**TABLE 5-2. PREVENTIVE MAINTENANCE CHECKS AND SERVICES,
 WEEKLY SCHEDULE (OPERATOR MAINTENANACE CATEGORY)**

INTERVAL AND SEQUENCE NO.			ITEM TO BE INSPECTED	PROCEDURE	PARAGRAPH REFERENCE
BEFORE OPERATION	DURING OPERATION	AFTER OPERATION			
1	---	5	Cables	Check cables for cuts, kinks, breaks, or fraying. Repair any cuts in cable insulation by covering with rubber tape and then friction tape. Repair or replace all damaged cables.	Figures 1-1, 9-7, 9-8
2	---	6	Connectors	Check for bent or broken pins, or damaged threads. Clean dirt from contacts. Replace all damaged connectors.	Figure 4-3
3	---	---	Handles and latches (case and simulator test set)	Inspect handles, latches, and hinges for looseness. Replace or tighten as necessary.	Figures 1-1, 4-3
---	---	4	Exterior surfaces	Inspect exposed metal surfaces for rust and corrosion. Clean and touch-up paint as required.	Paragraphs 5-5 and 5-7.

TABLE 5-3. PREVENTIVE MAINTENANCE CHECKS AND SERVICES, MONTHLY SCHEDULE (ORGANIZATIONAL MAINTENANCE CATEGORY)

SEQUENCE NUMBER	ITEM TO BE INSPECTED	PROCEDURE	PARAGRAPH REFERENCE
1	Logic board A1	Inspect seating of logic board A1 unassociated connectors XA1A and XA1B.	Figures 9-5 and 9-6
2	Transformer terminals	Inspect terminals on power transformer T1. Make certain that all screws are tight and that no dirt or corrosion is evident.	Figure 9-3

SECTION VI

MAINTENANCE INSTRUCTIONS

6-1. GENERAL.

6-2. This section contains calibration check procedures, troubleshooting procedures, and other maintenance data. These procedures and data comprise the intermediate maintenance level of repair.

6-3. TEST EQUIPMENT REQUIRED.

6-4. The special tools and test equipment required to service the simulator test set are listed in Section II.

6-5. OPERATIONAL CHECKOUT.

6-6. GENERAL. The operational checkout procedures are to be performed at least once every 3 months or whenever it is necessary to evaluate the performance of the simulator test set. Remove the test set proper from the case by loosening six front panel screws and washers, and place the test set in the vertical position. (Refer to Section IX for all parts location illustrations.) Each of the following operational checks are independent of the other. However, the initial control settings should be observed and, if necessary, the +5- and +50-volt power supply outputs aligned before starting a particular operational check. The power supply alignment is described in paragraph 6-21. The initial control settings are as follows:

<u>Control</u>	<u>Setting</u>
PRF SEL	INT-H
FUNCTION	INT/EXT
TEST WORD switches (all)	up (on)
AUXILIARY PULSE ON-OFF	OFF
GO/OFF/NO-GO	OFF
MODE 4 REPLY ON-OFF	OFF
DISPARITY ON-OFF	OFF ON

6-7. INTERNAL TRIGGER CHECK. To check the three internal trigger ranges, proceed as follows:

a. Connect the internally triggered oscilloscope to the INT TRIG connector using an

RG-62A/U cable or equivalent and a tee connector at the oscilloscope end. Terminate the cable at the tee connector with 75 ohms to ground.

b. Check that each internal trigger pulse has the following characteristics:

Amplitude	6 to 10 volts
Pulse width	0.3 to 25 micro-seconds
Rise time	0.2 microsecond
Fall time	0.5 microsecond

c. Connect the input connector of the frequency counter to the tee connector at the INT TRIG connector on the simulator test set.

d. Adjust the INT PRF FREQ ADJ control for a counter indication of 10,000 pps.

e. Adjust A1R58 for a full-scale deflection of the PRF KHZ meter.

f. Readjust the INT PRF FREQ ADJ control until the PRF KHZ meter indicates a prf of 6,000 pps. The frequency counter readout should be between 5,500 and 6,500 pps.

g. Readjust the INT PRF FREQ ADJ control until the PRF KHZ meter indicates a prf of 2,000 pps. The frequency counter readout should be between 1,500 and 2,500 pps.

h. Rotate the INT PRF FREQ ADJ control fully counterclockwise. The frequency counter readout should be 1,000 pps maximum.

i. Set the PRF SEL switch to the INT-MED position. Vary the INT PRF FREQ ADJ control from the fully clockwise position to the fully counterclockwise position, observing the readout of the frequency counter. The readout should be 100 pps maximum (for the counterclockwise position) and 1,000 pps minimum (for the clockwise position).

j. On the oscilloscope, check that the internal trigger pulse characteristics are the same as the internal trigger pulse listed in step b.

Set and hold the SCALE switch in the XI position. Adjust the INT PRF FREQ ADJ

control for a full-scale deflection on the PRF KHZ meter. The frequency counter readout should be between 950 and 1,050 pps.

l. Continue to hold the SCALE switch in the XI position and adjust the INT PRF FREQ ADJ control for a PRF KHZ meter indication of 600 pps. The frequency counter readout should be between 550 and 650 pps.

m. Continue to hold the SCALE switch in the XI position and adjust the INT PRF FREQ ADJ control for a PRF KHZ meter indication of 200 pps. The frequency counter readout should be between 150 and 250 pps. Release the SCALE switch.

n. Set the PRF SEL switch to the INT-L position, Vary the INT PRF FREQ ADJ control from the fully counterclockwise position to the fully clockwise position, observing the readout of the frequency counter. The readout should be 10 pps maximum (at the counterclockwise position) and 100 pps minimum (for the clockwise position),

o. On the oscilloscope, check that the internal trigger pulse characteristics are the same as listed in step b.

p. Set the PRF SEL switch to the INT-MED position. Adjust the INT PRF FREQ ADJ control for an indication of 1,000 pps on the frequency counter.

q. Connect the oscilloscope to the MARKER connector using the tee connector and RG-62A/U cable (or equivalent), terminated in 510 ohms to ground, as described in step a. On the oscilloscope, use external trigger and connect the external trigger input of the oscilloscope to the INT TRIG connector on the simulator test set.

r. Check that the oscilloscope displays a 1-MHz pulse train. Adjust the MARKER AMPLITUDE control from the fully counterclockwise to the fully clockwise position, observing that the amplitude of the pulse train on the oscilloscope display varies. The maximum peak-to-peak amplitude should be 10 volts minimum with the MARKER AMPLITUDE control in the fully clockwise position.

s. Disconnect the oscilloscope from the MARKER connector and connect the frequency counter, The counter readout should be a marker frequency between 0.99 and 1.01 MHz.

6-8. EXTERNAL TRIGGER CHECK. To check the external trigger operation of the simulator test set, proceed as follows:

a. Using a tee connector and 75-ohm termination, connect the pulse generator to the simulator test set EXT TRIG connector. Set the pulse generator output for -4 to -40 volts, 0.5 to 1.0 microsecond at a prf of 1,000 pps.

b. Set the PRF SEL switch to the EXT position. The PRF KHZ meter should indicate approximately 1,000 pps.

c. Reverse the polarity of the pulse generator output to positive. The PRF KHZ meter indication should remain the same.

d. Connect oscilloscope channel A to the INT TRIG connector, terminated into 75 ohms to ground. Connect oscilloscope channel B to the tee connector at the EXT TRIG connector. Externally synchronize the oscilloscope to the pulse generator output.

e. Check that the jitter between the two triggers is 1.1 microseconds maximum.

6-9. TEST WORD CHECK. To check the test word operation, proceed as follows:

Perform the internal trigger check described in paragraph 6-7.

b. Connect oscilloscope channel A to the TEST WORD connector via a tee connector and a termination of 75 ohms to ground. Connect the external sync of the oscilloscope to the INT TRIG connector. Check that 37 pulses are displayed.

c. Vary the TEST WORD AM control from the fully counterclockwise to the fully clockwise position and check that the amplitude of the 37 pulses varies. The amplitude should be 5 volts maximum (in the counterclockwise position) and 35 volts minimum (in the clockwise position).

d. Check one of the 37 pulses for the following characteristics:

Pulse width	0.4 to 0.6 microsecond
Rise time	0.1 microsecond maximum
Fall time	0.2 microsecond maximum

e. Connect the oscilloscope channel B and 510-ohm termination to the MARKER connector and check that the pulses are spaced in 2-microsecond increments from the leading edge of the first pulse with a tolerance of ± 0.1 microsecond per pulse spacing (bit 23 is 44 ± 0.1 microseconds from bit 1, leading edge to leading edge), Disconnect channel B.

f. Sequentially set each TEST WORD switch to the off (down) position and check that the corresponding bit position is eliminated, Set each switch to the on (up) position after each check.

g. Set all but the first five TEST WORD switches to the off (down) position. Set the AUX PULSE ON-OFF switch to the ON position and rotate the AUX PULSE AM and AUX PULSE DELAY controls to the fully clockwise position. Check that an additional pulse is displayed after bit position 5.

h. Check that the characteristics of the additional pulse are as follows:

Amplitude	Same as test word
Pulse width	0.4 to 0.6 microsecond maximum
Rise time	0.1 microsecond maximum
Fall time	0.2 microsecond maximum

i. Rotate the AUX PULSE AM control to the fully counterclockwise position. The amplitude of the additional pulse at the TEST WORD connector remains unchanged.

j. Check that the leading edge of the additional pulse is spaced 10 microseconds minimum from the leading edge of the first bit position. Rotate the AUX PULSE DELAY control to the fully counterclockwise position and check that the leading edge of the additional pulse is now 0.7 microsecond minimum from the leading edge of the first bit position.

k. Connect oscilloscope channel B to the AUX PULSE connector using a tee connector and a termination of 75 ohms. Check that a single pulse is displayed which corresponds in position to the additional pulse.

1. Repeat step h, except amplitude.

m. Vary the AUX PULSE AM control between the fully clockwise and fully counterclockwise positions and check that the single pulse amplitude varies from 5 volts maximum (in the counterclockwise position) to 35 volts minimum (in the clockwise position).

n. Set the AUX PULSE ON-OFF switch to the OFF position. Check that the additional pulse in the first display disappears while the single pulse in the second display remains.

o. Set the GO/OFF/NO-GO switch to the GO position. The pulses for both oscilloscope channels should not be present. The PRF KHZ meter indication should remain the same. Disconnect the oscilloscope from the AUX PULSE connector.

p. Set the oscilloscope sweep speed to the 1 millisecond/cm range. Press the GO/NO-GO pushbutton. Four pulse trains should appear on the oscilloscope. Each pulse train should consist of five pulses.

q. Set TEST WORD switches 6 through 37 to the up (on) position and again press the 00/NO-GO pushbutton. Four pulse trains should appear on the oscilloscope with each pulse train consisting of 37 pulses.

r. Place the GO/OFF/NO-GO switch to the NO-GO position. Press the GO/NO-GO pushbutton. Check that three full pulse trains (37 pulses each pulse train) appear on the oscilloscope display.

s. Set the GO/OFF/NO-GO switch to the OFF position. Reset the oscilloscope sweep speed to initial setting.

6-10. MODE 4 REPLY CHECK. To check the mode 4 reply operation, proceed as follows:

a. Set the FUNCTION switch to the M4 TRIG position.

b. Connect the pulse generator to the MODE 4 TRIG connector via a tee connector. Adjust the pulse generator output for +1.5 to 5.0 volts pulses at a prf of 1,000 pps. Connect a termination of 91 ohms to the tee connector and adjust the pulse generator output pulse width to 0.3 to 3.0 microsecond.

c. Set the MODE 4 REPLY switch to the ON position. The PRF KHZ meter indication should be 1,000 pps.

d. Using tee connectors and terminations of 91 and 75 ohms, respectively, connect oscilloscope channel A to the MODE 4 REPLY connector and channel B to the TEST WORD connector.

e. The oscilloscope channel A display should be three pulses with the following characteristics:

Pulse width	0.3 to 0.7 microsecond
Rise time	0.1 microsecond maximum
Fall time	0.25 microsecond maximum
Pulse spacing (consecutive pulses)	1.6 to 2.0 microseconds leading edge to leading edge.

f. Rotate the MODE 4 REPLY AM control from the fully counterclockwise to the fully clockwise positions. The amplitude of the three pulses displayed on the oscilloscope should vary from 2 volts maximum (in the counterclockwise position) to 35 volts minimum (in the clockwise position).

g. Rotate the MODE 4 REPLY DELAY control to the fully counterclockwise position. The leading edge of the first of the three pulses displayed on the oscilloscope (channel A) should be 200 microseconds maximum from the leading edge of the first pulse of the test word displayed on channel B.

h. Rotate the MODE 4 REPLY DELAY control to the fully clockwise position. The leading edge of the first of the three pulses should be 276 microseconds minimum from the leading edge of the first pulse of the test word.

i. Set the MODE 4 REPLY ON-OFF switch to the OFF position. The three-pulse display on channel A of the oscilloscope should no longer be present.

j. Set the DISPARITY switch to the DL-1 position. Rotate the DISPARITY DELAY control to the fully counterclockwise position. Connect oscilloscope channel A to the MODE 4 DISPARITY connector, using a tee connector and a termination of 91 ohms. A single pulse should be displayed on oscilloscope channel A. The leading edge of the pulse should be 8 microseconds maximum from the leading edge of the

first pulse of the test word displayed on oscilloscope channel B.

k. Rotate the DISPARITY DELAY control to the fully clockwise position. The leading edge of the single pulse should be 76 microseconds minimum from the leading edge of the first pulse of the test word. The single pulse should have the following characteristics:

Amplitude	3 to 5 volts
Pulse width	0.3 to 1.0 microsecond
Rise time	0.15 microsecond maximum
Fall time	0.5 microsecond maximum

l. Set the DISPARITY switch to the DL-2 position. The leading edge of the single pulse should be 276 microseconds minimum from the leading edge of the first pulse in the test word.

m. Rotate the DISPARITY DELAY control to the fully counterclockwise position. The leading edge of the single pulse should be 194 microseconds maximum from the leading edge of the first pulse in the test word.

n. Check the pulse characteristics of the single pulse. The characteristics should be the same as in step k.

o. Set the DISPARITY switch to the OFF position. The single pulse should disappear.

6-11. INSPECTION AND PREVENTIVE MAINTENANCE.

6-12. Refer to paragraph 5-3 for all inspection and preventive maintenance procedures and schedules.

6-13. TROUBLESHOOTING.

6-14. The troubleshooting procedures are contained in the logic flow chart shown in figure 6-1. Start with the upper left box and proceed to the succeeding box when a normal (or "yes") indication is obtained. When an abnormal (or "no") indication is obtained, proceed to the box immediately below. This branching process should be followed until the trouble has been isolated to a specific circuit or functional group of circuits specified in the circles. Once the trouble has been isolated,

use standard circuit troubleshooting techniques to locate the defective component. (See figures 8-1 and 8-2 for the logic and power supply circuits schematic diagrams, respectively, and the parts location diagrams in Section IX.) After repair has been effected, return to the box in the trouble shooting flow chart in which the initial abnormal indication was detected and resume the procedure.

6-15. REPAIR.

6-16. Use standard replacement procedures when replacing a defective integrated circuit, transistor, diode, etc. There are no unusual procedures to follow except when defective parts have been replaced on power supply board A2. If Q4 through Q7, VR2, R9, R10, or R11 have been replaced, proceed to step g. If Q1, Q2, Q3, CR3, R3, or R4 have been replaced, proceed to step a. If one or more components from both the +5- and +50-volt power circuits have been replaced, proceed to step a. Then, if the meter indication is normal, proceed to step g.

a. Connect a de voltmeter across A2E6 and A2E3 (ground). The meter indication should be between +4.95 and +5.05 volts. If the indication is not within tolerance, proceed to step b. If the indication is within tolerance, no further check is required.

b. Set the ON-OFF switch to the OFF position. Disconnect the output wire from A2E6.

c. Connect a 10-ohm, 2.5-watt (minimum) resistive load across A2E6 and A2E3 and reconnect the meter leads. Set the ON-OFF switch to the ON position.

d. Adjust potentiometer R14 for a meter indication between +4.95 and 5.05 volts.

e. Set the ON-OFF switch to the OFF position. Disconnect the lead and reconnect the output lead to A2E6.

f. Set the ON-OFF switch to the ON position. Check that the meter indication is still within the tolerance limits.

g. Connect the de voltmeter across A2E1 and A2E3 (ground). The meter indication should be between +49.5 and +50.5 volts. If the indication is not within tolerance, proceed

to step h. If the indication is within tolerance, no further check is required.

h. Set the ON-OFF switch to the OFF position. Disconnect the output lead from A2E1.

i. Connect a 150-ohm, 17-watt (minimum) resistive load across A2E1 and A2E3 and reconnect the meter leads. Set the ON-OFF switch to the ON position.

j. Adjust potentiometer R15 for a meter indication between +49.5 and +50.5 volts.

k. Set the ON-OFF switch to the OFF position. Disconnect the load and reconnect the output lead to A2E1.

l. Set the ON-OFF switch to the ON position and check that the meter indication is still within the tolerance limits.

6-17. TEST.

6-18. After repair has been effected, perform the performance checks described in paragraphs 6-5 through 6-10. If any of the components mentioned in paragraph 6-10 have been replaced, check the corresponding output voltage from power supply board A2 and align, if necessary, associated potentiometer A2R14 and A2R15, as described in paragraph 6-16.

6-19. CALIBRATION.

6-20. Calibration of the simulator test set is limited only to the PRF KHZ meter. Perform the procedure described in paragraph 6-7 With the simulator test set placed in the vertical position.

6-21. POWER SUPPLY ALIGNMENT.

6-22. To check and align the +5- and +50-volt outputs of power supply board A2, proceed as follows:

a. Connect a de voltmeter across test point A2TP2 and ground. The meter indication should be between +4.95 and +5.05 volts. Adjust potentiometer R14, if necessary, for a normal indication.

b. Connect the meter across A2TP3 and ground. The meter indication should be between +49.5 and +50.5 volts. Adjust potentiometer R15, if necessary, for a normal indication.

c. Disconnect the meter leads.

SECTION VII
DEPOT OVERHAUL STANDARDS

7-1. APPLICABILITY OF DEPOT INSPECTION STANDARDS.

7-2. The simulator test set must be tested thoroughly after rebuild or repair to ensure adequate performance standards before returning the equipment to stock and reissue. Use the tests described in this section to measure the performance of the repaired test set. It is mandatory that repaired equipment to be reissued, or returned to stock for reissue, meet all of the Performance standards described in this section.

7-3. APPLICABLE REFERENCES.

7-4. REPAIR STANDARDS. Applicable procedures for the depot performing- this test and the general standards for repaired electronic

equipment described in TB SIG-355-1, TB SIG-355-2, and TB SIG-355-3 form a part of the requirements for testing this equipment.

7-5. TECHNICAL PUBLICATIONS. No technical publications are required other than this manual.

7-6. MODIFICATION WORK ORDERS. Perform all modification work orders applicable to this equipment before performing the specified tests. DA Pam 310-7 lists all available MWO'S.

7-7. TEST FACILITIES REQUIRED.

7-8. The items required for depot testing are listed in table 7-1.

TABLE 7-1. TEST FACILITIES REQUIRED

ITEM	TECHNICAL MANUAL	COMMON NAME
Multimeter TS-352B	TM 11-6625-366-15	Multimeter
Oscilloscope AN/USM-281A		Oscilloscope
Electronic Counter AN/USM-207A	TM 11-6625-700-10	Frequency counter
Pulse Generator AN/UPM-15A		Pulse generator
75-ohm, Resistive Terminal (one 5-watt; two 1/4-watt)		75- ohm terminat ion
91-ohm, 1/4-watt Resistive Termination (2 required)		91- ohm termination
510-ohm, 1/4-watt, Resistive Termination		510-ohm termination

7-9. Most of the tests will be performed under the conditions described below and as shown in figures 7-1 through 7-4. Testing will be simplified if connections and panel control settings are made initially and modifications are made as required for the individual tests.

- a. Remove the simulator test set from the case by loosening the six front-panel captive screws.
- b. Connect power cable WI from a 115-volt, 60- or 400-Hz power source to POWER connector J11.

Using tee connectors, connect 75-ohm terminations to the TEST WORD, AUX PULSE, and INT TRIG connectors, 9 1-ohm terminations to the MODE 4 DISPARITY and MODE 4 REPLY connectors, and a 510-ohm termination to the MARKER connector.

- d. Set the front-panel controls as follows:

<u>CONTROL</u>	<u>POSITION</u>
PRF SEL switch	INT-H
TEST WORD switches (37). . .	up (on)
AUX PULSE switch	OFF
GO/OFF/NO-GO switch	OFF
FUNCTION switch	INT/EXT
INT PRF FREQ ADJ control . . .	Fully CCW
TEST WORD AMPLITUDE control	Fully CCW
MARKER AMPLITUDE control	Fully CCW
MODE 4 REPLY switch	OFF
DISPARITY switch	OFF

- e. Set the power ON-OFF switch to the ON position and check that the POWER indicator is lighted.

7-10. INTERNAL TRIGGER OPERATION TESTS.

7-11. To perform the internal trigger operation tests, proceed as follows:

- a. Using a tee connector, connect the simulator test set to the oscilloscope as shown in figure 7-1A. Check for the following internal

trigger pulse characteristics on the oscilloscope:

- Amplitude +6 to +10 volts
- Pulse width 0.3 to 25 microseconds
- Rise time 0.2 microsecond
- Fall time 0.5 microsecond

- b. Connect the simulator test set to the frequency counter as shown in figure 7-1B. Starting with the INT PRF FREQ ADJ control in the maximum counterclockwise position, adjust the control until the frequency counter indicates a prf of 10,000 pps. Adjust potentiometer R58 on logic board A1 for a full-scale indication on the PRF KHZ meter.

- c. Adjust the INT PRF FREQ ADJ control until the PRF KHZ meter indicates 6,000 pps. Check that the frequency counter indicates a prf between 5,500 and 6,500 pps.

- d. Adjust the INT PRF FREQ ADJ control until the PRF KHZ meter indicates 2,000 pps. Check that the frequency counter indicates a prf between 1,500 and 2,500 pps.

- e. Rotate the INT PRF FREQ ADJ control fully counterclockwise and check that the frequency counter indicates a prf of 1,000 pps maximum.

- f. Set the PRF SEL switch to the INT-MED position. While observing the indication on the frequency counter, rotate the INT PRF FREQ ADJ control fully counterclockwise and then fully clockwise. The frequency counter should indicate a prf of 100 pps maximum in the counterclockwise position and 1,000 pps minimum in the clockwise position.

- g. Using the oscilloscope, check for the pulse characteristics in step a.

- h. Hold the SCALE switch in the X1 position and adjust the INT PRF FREQ ADJ control until a full-scale indication is obtained on the PRF KHZ meter. Check that the frequency counter indicates a prf between 950 and 1,050 pps.

- i. Hold the SCALE switch in the X1 position and adjust the INT PRF FREQ ADJ control until the PRF KHZ meter indicates 600 pps. Check that the frequency counter indicates a prf between 550 and 650 pps.

Hold the SCALE switch in the X1 position and adjust the INT PRF FREQ ADJ control

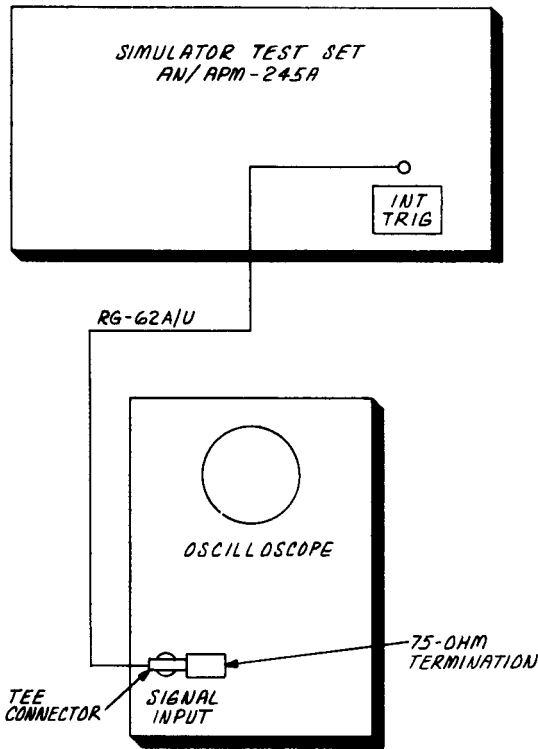

A. INT TRIG PULSE CHARACTERISTICS TEST

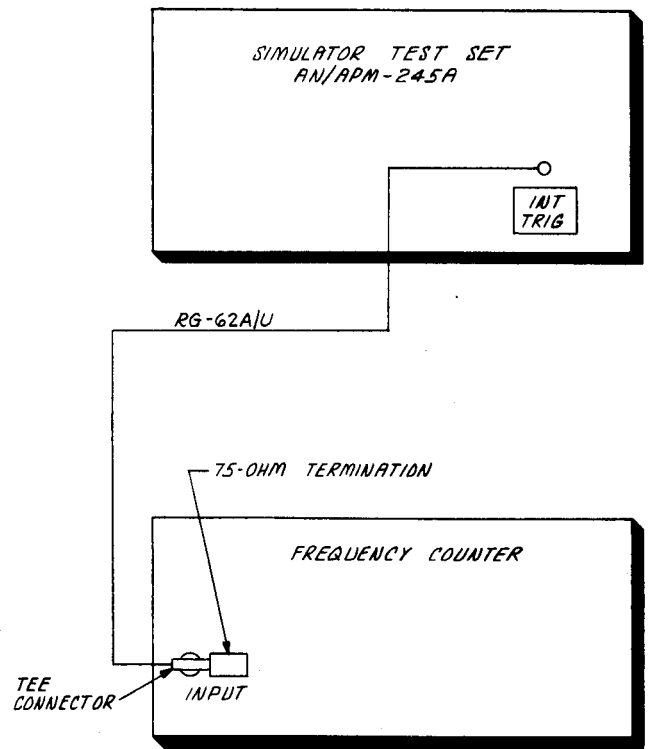

B. INT TRIG MEASUREMENTS TEST

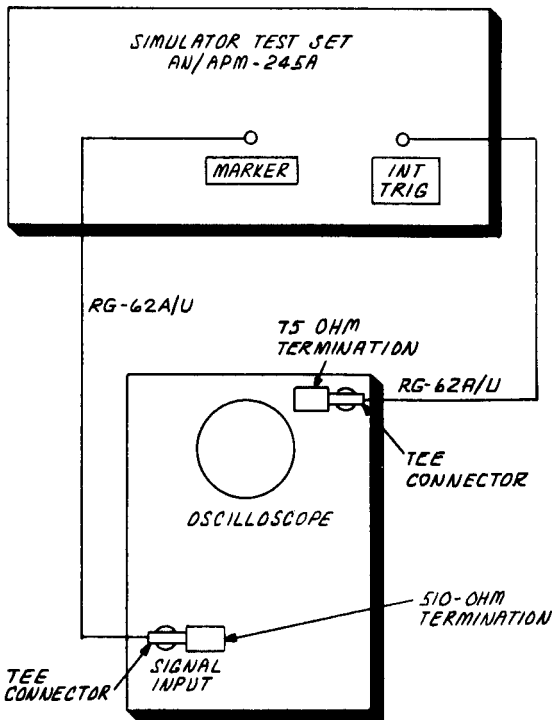

C. MARKER PULSE CHARACTERISTICS TEST

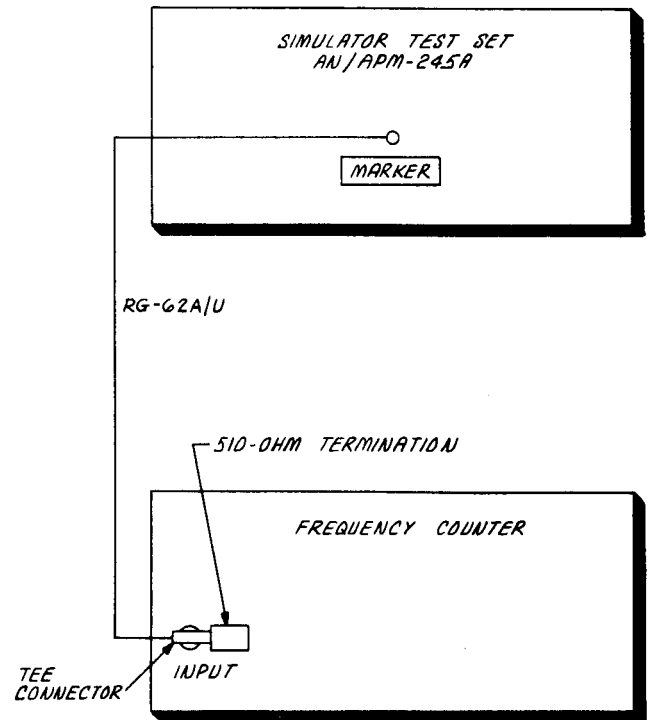

D. MARKER FREQUENCY MEASUREMENT TEST

Figure 7-1. Internal Trigger Tests, Test Setup

until the PRF KHZ meter indicates 200 pps. Check that the frequency counter indicates a prf between 150 and 250 pps.

k. Set the PRF SEL switch to the INT-L position. While observing the indication on the frequency counter, rotate the INT PRF FREQ ADJ control fully counterclockwise and then fully clockwise. The frequency counter should indicate a prf of 10 pps maximum for the counterclockwise position and 100 pps minimum for the clockwise position.

l. Using the oscilloscope, check for the pulse characteristics in step a.

m. Set the PRF SEL switch to the INT MED position. Adjust the INT PRF FREQ ADJ control until the frequency counter indicates a prf of 1,000 pps.

n. Connect the simulator test set to the oscilloscope as shown in figure 7-1C. Set the oscilloscope for external triggering. While observing the oscilloscope, rotate the MARKER AMPLITUDE control fully counterclockwise and then fully clockwise. Check the amplitude variation of the marker pulses throughout the range; amplitude should vary between 0 (ccw) and 10 (cw) volts minimum.

Connect the simulator test set to the frequency counter as shown in figure 7-1D. Check that the frequency counter indicates a frequency between 0.99 and 1.01 MHz.

7-12. EXTERNAL TRIGGER OPERATION TESTS.

7-13. To perform the external trigger operation tests, proceed as follows:

a. Set the PRF SEL, switch to the EXT position.

b. Using an RG-62A/U cable (or equivalent), connect the pulse generator to the EXT TRIG connector. Adjust the pulse generator output for -4 to -40 volts, 0.5 to 1.0 microsecond at a prf of 1,000 pps. Check that the PRF KHZ meter indicates approximately 1,000 pps.

c. Reverse the polarity of the pulse generator output from negative to positive. Check that the PRF KHZ meter indicates approximately 1,000 pps.

d. Connect the simulator test set, oscilloscope, and pulse generator as shown in figure 7-2. Set the oscilloscope for external triggering. Check that the jitter between the external and internal triggers, as displayed on the oscilloscope, is 1.1 microseconds maximum.

7-14. TEST WORD OUTPUT TESTS.

7-15. To perform the test word output tests, proceed as follows:

Set the PRF SEL switch to the INT MED position and adjust the INT PRF FREQ ADJ control until the PRF KHZ meter indicates 1,000 pps.

b. Connect the simulator test set to the oscilloscope as shown in figure 7-3A. Set the oscilloscope for external triggering. Check that 37 pulses (bits) appear on the oscilloscope display.

c. While observing the oscilloscope, rotate the TEST WORD AMPLITUDE control fully counterclockwise and then fully clockwise. The test word amplitude variation should be uniform. The amplitude should be 5 volts maximum for the counterclockwise position and 35 volts minimum for the clockwise position.

d. Adjust the TEST WORD AMPLITUDE control until the amplitude of the test word is 35 volts.

e. Check that each of the test word pulses has the following characteristics:

Pulse width . . . 0.4 to 0.6 microsecond

Rise time . . . 0.1 microsecond

Fall time . . . 0.2 microsecond

f. Using an RG-62A/U cable (or equivalent), connect the MARKER connector to the other channel input of the oscilloscope. Check that the 2-microsecond spacing of each test word pulse (bit) is within ± 0.1 microsecond of the leading edge of the first bit (e.g., the leading edge of bit 23 should be spaced 44 ± 0.1 microseconds from the leading edge of bit 1).

g. Set TEST WORD switch 1 to the down (off) position and check that bit 1 of the test word disappears from the oscilloscope display.

h. Repeat step g. for bits 2 through 37 using the corresponding TEST WORD switches.

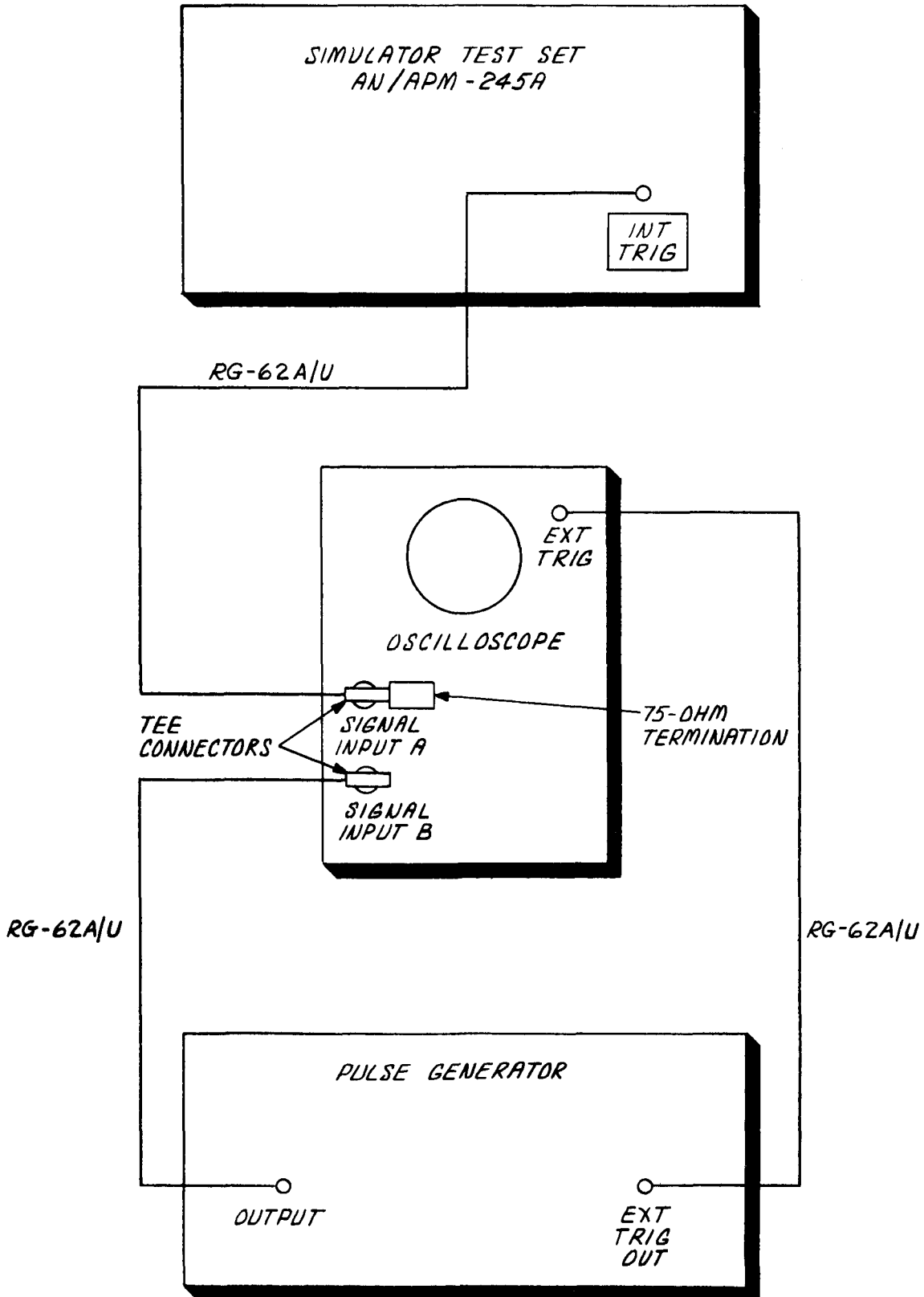

Figure 7-2. Mode 4 Tests, Test Setup

i. Set TEST WORD switches 1 through 5 to the up (on) position and the AUX PULSE switch to the ON position. Rotate the AUX PULSE DELAY control fully clockwise and observe that an auxiliary pulse appears after the first five bits of the test word, delayed 10 microseconds minimum from the leading edge of bit 1. Check that the characteristics of the auxiliary pulse are identical to those specified in steps c. and e.

j. While observing the oscilloscope, rotate the AUX PULSE DELAY control from the fully clockwise to the fully counterclockwise position. The auxiliary pulse position variation should be uniform. The auxiliary pulse should lead the leading edge of bit 1 by 0.7 microsecond minimum when the AUX PULSE DELAY control is in the fully counterclockwise position.

k. Rotate the AUX PULSE AM control and check that the control has no effect on the amplitude of the auxiliary pulse displayed on the oscilloscope.

l. Connect the simulator test set to the oscilloscope as shown in figure 7-3B. Set the oscilloscope for external triggering. Rotate the AUX PULSE AM and AUX PULSE DELAY controls to the fully clockwise position. Check that the auxiliary pulse of the upper oscilloscope trace is in coincidence with the auxiliary pulse displayed on the lower trace. Also check for the following pulse characteristics on the oscilloscope:

- Amplitude. . . . 35 volts minimum
- Pulse width . . . 0.4 to 0.6 microsecond
- Rise time . . . 0.1 microsecond maximum
- Fall time 0.2 microsecond maximum

m. Rotate the AUX PULSE AM control to the fully counterclockwise position and check that the amplitude of the auxiliary pulse displayed on the lower trace of the oscilloscope is 5 volts maximum. Also check that the characteristics of this pulse are identical to those specified in step l.

n. Rotate the TEST WORD AM control and check that the control has no effect on the amplitude of the auxiliary pulse displayed on the lower trace of the oscilloscope.

o. Connect the simulator test set to the oscilloscope as shown in figure 7-3A. Set the

oscilloscope for external triggering. Set the GO/OFF/NO-GO switch to the GO position. Check that the test word is not displayed on the oscilloscope.

p. Set the oscilloscope sweep control to the 1 ins/cm range. Momentarily depress the GO/NO-Go pushbutton and check that four pulse-train groups of the selected five-bit code are displayed on the oscilloscope. (If the program jumper wires were reconnected, see figure 8-1, Note 3, to determine the number of pulse-train groups.)

q. Set all the TEST WORD switches to the up (on) position and momentarily depress the GO/NO-Go pushbutton. Check that four pulse-train groups of 37 bits are displayed on the oscilloscope. (Depress the GO/NO-GO pushbutton as many times as necessary to observe the oscilloscope display.)

r. Set the GO/OFF/NO-Go switch to the NO-GO position. Momentarily depress the GO/NO-GO pushbutton and check that three pulse-train groups of 37 bits are displayed on the oscilloscope. (If the program jumps r wires were reconnected, see figure 8-1, Note 3, to determine the number of pulse-train groups.)

7-16. MODE 4 REPLY OPERATION TESTS.

7-17. To perform the mode 4 reply operation test, proceed as follows:

a. Set the FUNCTION switch to the M4 TRIG position.

b. Connect the simulator test set, oscilloscope, and pulse generator as shown in figure 7-4. Set the oscilloscope and pulse generator for external triggering. Adjust the pulse generator output for +1.5 to 5 volts, 0.3 to 3.0 microseconds with a rise time of 0.1 microsecond. Adjust for a 2-microsecond delay between this pulse and the external trigger input to the pulse generator.

c. Set the FUNCTION switch to the INT/EXT position and the PRF SEL switch to the INT-MED position. Rotate the INT PRF FREQ ADJ control until the PRF KHZ meter indicates 1,000 pps.

d. Set the MODE 4 REPLY switch to the ON position. Rotate the MODE 4 REPLY AM control to the fully clockwise position and the MODE 4 REPLY DELAY control to the fully

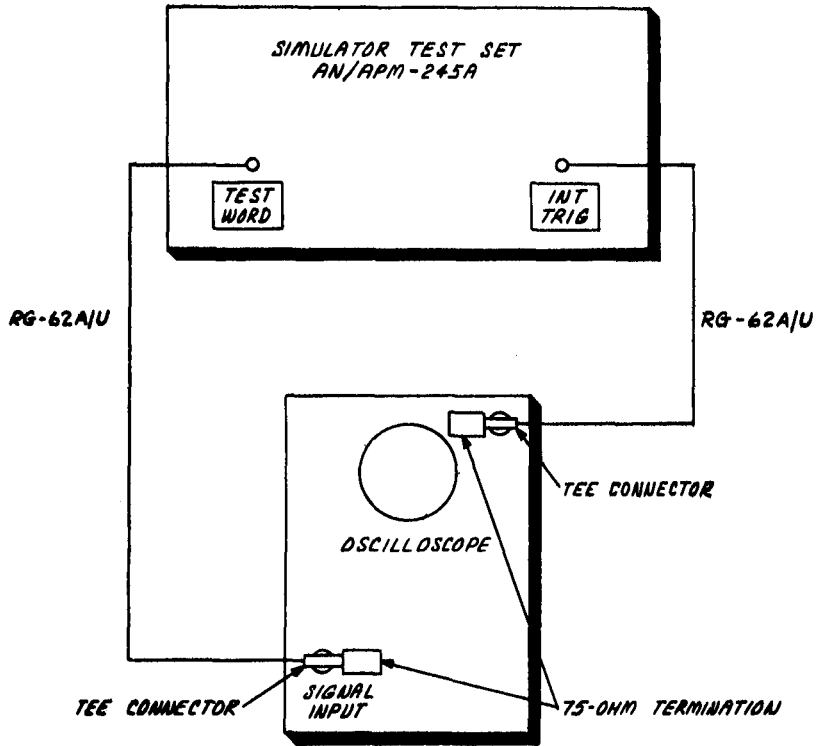

A. TEST WORD PULSES CHARACTERISTICS TEST

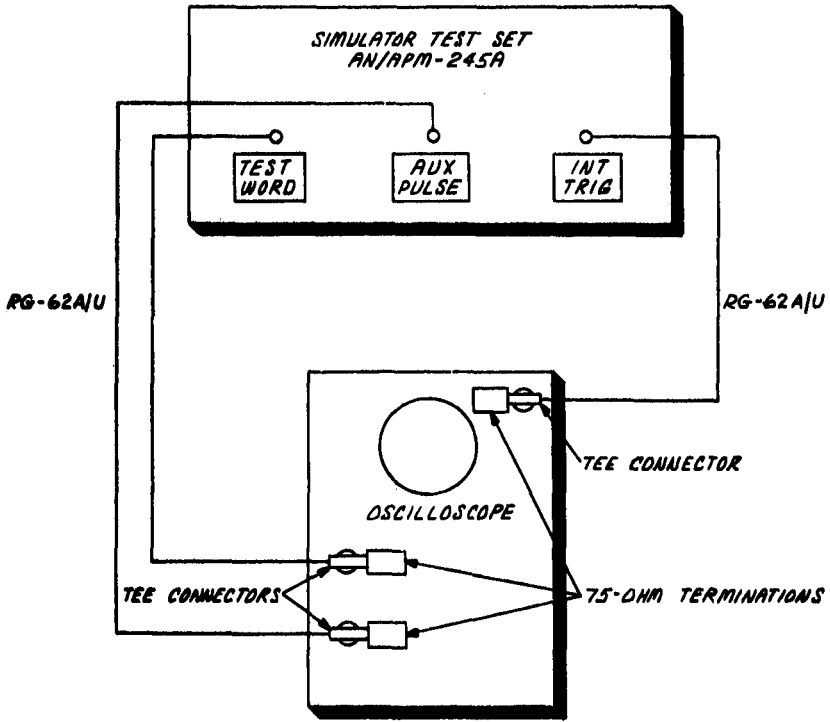

B. AUXILIARY PULSE CHARACTERISTICS TEST

Figure 7-3. Test Word Output Tests, Test Setups

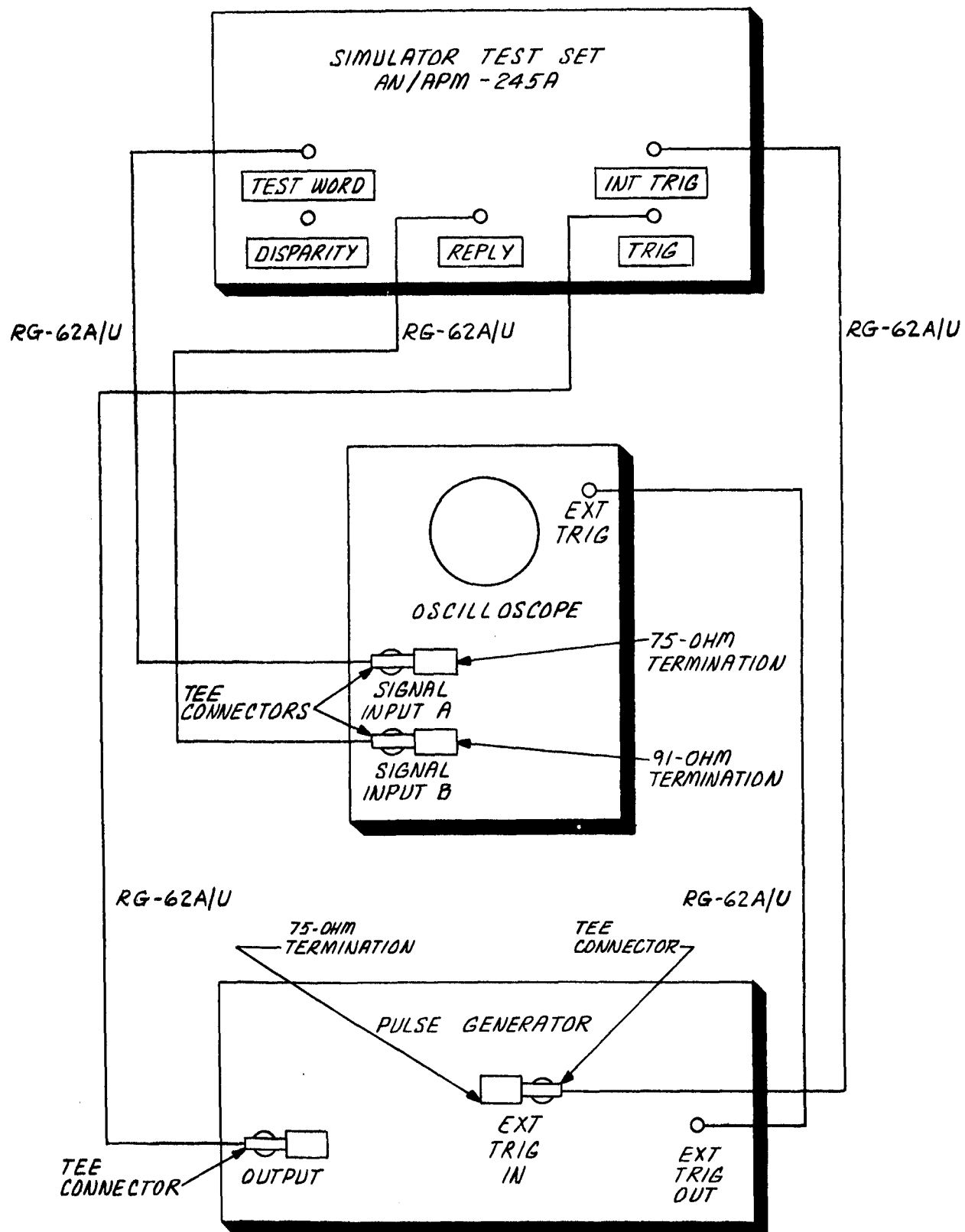

Figure 7-4. External Trigger vs. Internal Trigger Jitter Test, Test Setup

counterclockwise position. Check that the leading edge of the first pulse of the mode 4 reply train (three pulses spaced 1.8 microseconds apart) is delayed 200 microseconds maximum from the leading edge of the first bit of the test word.

e. While observing the oscilloscope, rotate the MODE 4 REPLY DELAY control from the fully counterclockwise to the fully clockwise position. The mode 4 reply train delay should vary. Also, the leading edge of the first pulse should be 276 microseconds minimum from the leading edge of the first test word bit.

f. Check for the following mode 4 reply train characteristics on the oscilloscope:

Amplitude. . . . 2 volts max with
 MODE 4 REPLY AM
 control set fully ccw;
 35 volts min with con-
 trol set fully cw

Pulse width. . . . 0.3 to 0.7 µsecond

Rise time. . . . 0.1 µsecond max

Fall time. . . . 0.25 µsecond max

Pulse spacing. . . 1.6 to 2.0 µseconds
 between leading edges
 of consecutive pulses

g. Set the MODE 4 REPLY switch to the OFF position and check that the mode 4 reply train disappears from the oscilloscope display.

h. Set the DISPARITY switch to the DL-1 position and rotate the DISPARITY DELAY control to the fully counterclockwise position.

i. Disconnect an RG-62A/U cable from the REPLY connector and reconnect the cable to the DISPARITY connector, Check that the leading edge of the disparity pulse is delayed 8.0 microseconds maximum from the leading edge of the first test word bit.

j. Rotate the DISPARITY DELAY control to the fully clockwise position and check that the leading edge of the disparity pulse is delayed 76 microseconds minimum from the leading edge of the first test word bit.

k. Check for the following disparity pulse characteristics on the oscilloscope:

Amplitude. . . . 3 to 5 volts

Pulse width . . . 0.3 to 1.0 µsecond

Rise time. . . . 0.15 µsecond max

Fall time0.5 µsecond max

l. Set the DISPARITY switch to the OFF position and check that the disparity pulse disappears from the oscilloscope display.

m. Set the DISPARITY switch to the ON position, set the DISPARITY DL-1/OFF/DL-2 switch to the DL-2 position, and rotate the DISPARITY DELAY control to the fully counterclockwise position. Check that the leading edge of the disparity pulse is delayed 194 microseconds maximum from the leading edge of the first test word bit.

n. Rotate the DISPARITY DELAY control to the fully clockwise position and check that the leading edge of the disparity pulse is delayed 276 microseconds minimum from the leading edge of the first test word bit.

o. Check that the disparity pulse displayed on the oscilloscope has the same characteristics as those described in step k.

p. Set the power ON-OFF switch to the OFF position and disconnect the oscilloscope and pulse generator.

7-18. MODE 4 CONNECTORS RESISTANCE TESTS.

7-19. To perform the mode 4 connectors resistance tests, proceed as follows:

a. Set the power ON-OFF switch to the OFF position.

b. Set the multimeter for use as an ohmmeter and connect the multimeter leads across the center conductor and outer shell of the VIDEO connector. The multimeter indication should be from 81 to 101 ohms.

c. Check for continuity between the pins of MODE 4 connector J1 and the center conductor of the connector indicated below:

<u>From</u>	<u>To</u>
J1-a	DISPARITY connector
J1-b	TRIG connector
J1-c	VIDEO connector
J1-d	REPLY connector

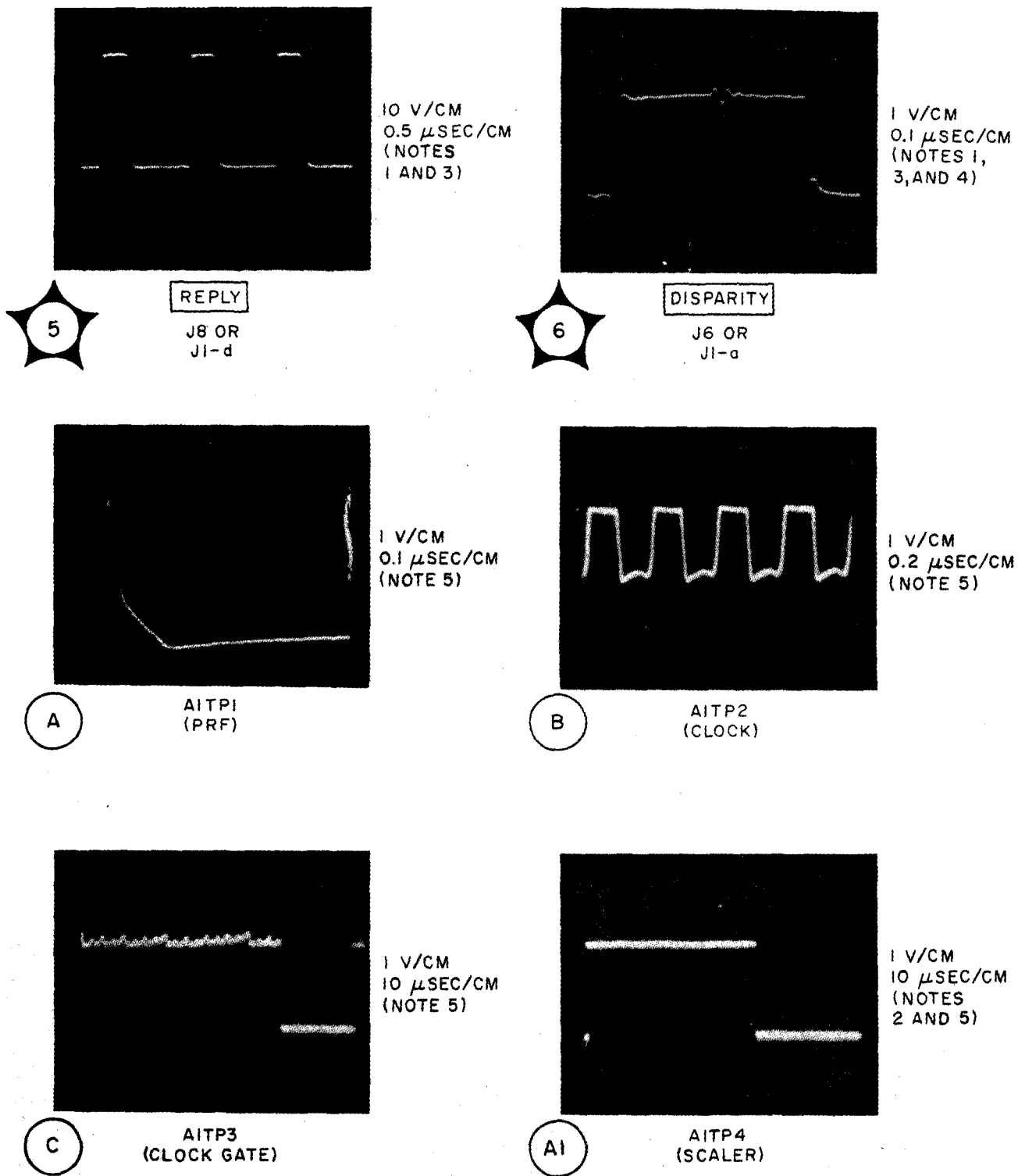
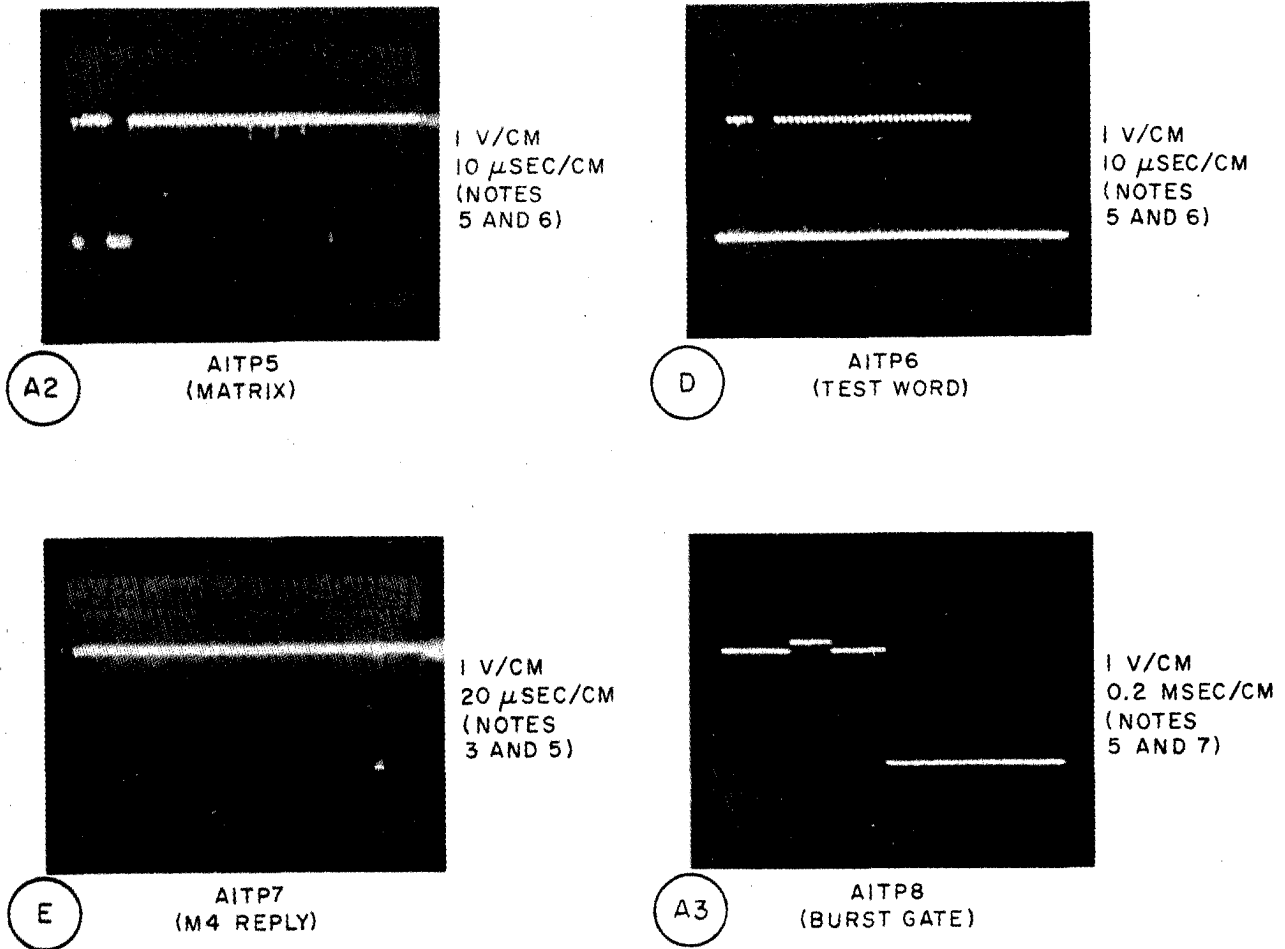

Figure 8-4. Simulator Test Set, Waveforms (Sheet 2 of 3)



NOTES:

1. SET PRF FOR 3KHZ.
GO/OFF/NO-GO S44: OFF
2. TEST WORD SI-S37: UP (ON)
AUX PULSE ON-OFF S41: OFF
3. CONNECT MODE 4 TRIGGER SOURCE TO MODE 4 TRIG J10.
MODE 4 REPLY ON-OFF S40: ON
4. DISPARITY DL-1/OFF/DL-2 S42: DL-1 OR DL-2, AS APPLICABLE.
5. SET PRF FOR 1KHZ.
EXCEPT WHEN NOTE 7 IS APPLICABLE:
GO/OFF/NO-GO S44: OFF
6. TEST WORD SI-S4, S8-S37: UP (ON)
TEST WORD S5, S6, S7: DOWN (OFF)
7. GO/NO-GO S44: GO OR NO-GO
GO/NO-GO S43: PRESS REPEATEDLY

Figure 8-4. Simulator Test Set, Waveforms (Sheet 3 of 3)

SECTION IX

ILLUSTRATED PARTS BREAKDOWN

9-1. INTRODUCTION.

9-2. This Illustrated Parts Breakdown lists, describes and illustrates the complete assembly, subassemblies and detail parts of the Simulator Test Set AN/APM-245A. This equipment is manufactured by Hazeltine Corporation, Greenlawn, N. Y., under contract number F33657-71-C-0598.

9-3. This Illustrated Parts Breakdown is divided into the following four groups: INTRODUCTION, GROUP ASSEMBLY PARTS LIST, NUMERICAL INDEX AND REFERENCE DESIGNATION INDEX.

9-4. GROUP ASSEMBLY PARTS LIST.

9-5. The Group Assembly Parts List is divided into the major assemblies of the Simulator Test Set AN/APM-245A. Figure 9-1 illustrates the complete assembly.

9-6. The major assemblies are broken down into subassemblies and detail parts. Each assembly shown in the Group Assembly Parts List is directly followed by a listing of its detail parts properly indented to show their relationship to the assembly. Detail parts of assemblies and subassemblies are illustrated and listed in order of disassembly. Each assembly is illustrated to a degree necessary to identify its detail parts. When an assembly appears on an illustration and it is not broken down at that location, reference is made to the illustration on which it appears for its detail breakdown. All assemblies are referred to their next higher assembly when they are illustrated and listed for separate detail breakdown. For example, figure 9-2, index number 1 lists "TEST SET (See fig. 9-3 for detail breakdown. "The first listing at figure 9-3 then lists "TEST SET (See fig. 9-2 for NHA)."

9-7. FIGURE AND INDEX NUMBERS. The Figure and Index Number consists of three numbers separated by dashes. The number preceding the first dash is the section number of this manual, The number preceding the second dash is the number of the illustration

on which the part is shown. The number following the final dash is the number assigned to the part on a particular illustration.

9-8. PART NUMBERS. Part numbers listed in the Part Number column are the manufacturers' and government standard part numbers, Subassemblies whose detail parts are welded or permanently attached are listed as "No Number" in the Part Number column. The Description column lists the noun name and the part numbers of the welded parts. For example, see figure and index number 9-3-63.

9-9. DESCRIPTION. The description column describes the assemblies, subassemblies and detail parts of the complete article, properly indented to show assembly and disassembly relationship. The description for each part consists of the item name assigned by the design manufacturer. In the case of government standard parts, only the applicable noun name is given.

9-10. Attaching parts follow immediately the parts they attach and preceding any details of that item if the item is an assembly. Attaching parts are captioned "(ATTACHING PARTS)" and are followed by the separating symbol "---*---" to aid in distinguishing them from preceding and subsequent listing of parts.

9-11. UNITS PER ASSEMBLY. The number listed in this column indicates the total quantity used per assembly, In certain instances it represents the total quantity of the part or assembly used at a particular location indexed on an illustration. The use of the abbreviation "REF" in the Unit Per Assembly column indicates that the listing for that assembly or part has been repeated to provide reference to its previous listing, In such cases the description column will refer to the next higher assembly, where the quantity per assembly will appear.

9-12. MANUFACTURERS' (VENDORS') CODE SYMBOLS. For all vendor items the manufacturers' code symbol, in accordance with Federal Supply Code for Manufacturers Cataloging Handbook H4-1 and H4-2, appears in the

description column in parentheses immediately following the description of the part. The absence of a code or manufacturer's name following a part description indicates that the item is either a government standard or a prime contractor's part. The code symbols used in this Illustrated Parts Breakdown together with the names and addresses of the manufacturers are as follows:

VENDORS' CODE		VENDORS' CODE (Cont)	
Code	Vendors' Name and Address	Code	Vendors' Name and Address
00779	AMP Inc. Harrisburg, Pa, 17105	25936	A and M Instrument Inc. Expando Meter Division Great Neck, N, Y. 11022
01121	Allen-Bradley Co. Milwaukee, Wis. 53204	27193	Cutler -Hammer Inc. Specialty Products Division Milwaukee, Wis. 53216
02660	Bunker-Ramo Corp. Am phenol Connector Division Broadview, 111. 60153	32897	Erie Technological Products Inc. Erie Frequency Control Div. Carlisle, Pa. 17013
02875	Hudson Tool and Die Co. Inc. Newark, N.J. 07105	36555	F. J. Littell Machine Co. Chicago, Ill. 60613
04713	Motorola Inc. Semiconductor Products Division Phoenix, Ariz. 85008	42498	National Radio Co. Inc. Melrose, Mass. 02176.
05397	Union Carbide Corp. Materials Systems Division Cleveland, Ohio 44101	46384	Penn Engineering and Mfg. Corp. Doylestown, Pa. 18901
06540	Amatom Electronic Hardware Division of Mite Corp. New Rochelle, N. Y. 10801	56289	Sprague Electric Co. North Adams, Mass. 01247
08795	Rayclad Tubes Inc. Melo Park, Calif. 94025	71279	Cambridge Thermionic Corp. Cambridge, Mass. 02138
09922	Burndy Corp. Norwalk, Ct. 06852	71744	Chicago Miniature Lamp Works Chicago, Ill. 60640
13103	Thermally Co. Dallas, Tex. 75247	72619	Dialight Corp. Brooklyn, N, Y, 11237
18915	The Birtcher Corp. Industrial Division Monterey Park, Calif. 91754	72962	Elastic Stop Nut Division of Amerace ESNA Corp. Union, N. J, 07083
19178	Zero Mfg. Co. East Division Monson, Mass. 01057	75237	The Kaynar Co. Division of Reiner Industries Inc. Pico-Rivera, Calif. 90660
		75376	Kurz & Kasch Inc. Dayton, Ohio 45401
		79963	Zierick Mfg. Co. Mt. Kisco, N. Y. 10549
		86684	RCA Corp. Electronic Components Harrison, N, J, 07029

9-13. NUMERICAL INDEX.

9-14. The Numerical Index includes all part numbers shown in the Part Number column of the Group Assembly Parts List. The prime contractor's specification control drawing numbers listed in the Description column are also included in the Numerical Index. The figure and index number, quantity per article, Air Force and Navy Source/Repair/Recoverability codes are shown for these parts. For Government Standard Parts, only the first figure and index number that occurs is listed.

9-15. Subassemblies listed as "No Number" in the Part Number column of the Group Assembly Parts List are listed in the Numerical Index by noun name. Detail parts that comprise the "No Number" subassembly are also listed in the Numerical Index. The Figure and Index Number and Quantity Per Article columns are annotated to indicate that the detail part is not to be requisitioned and reference should be made to the Next Higher Assembly. For example, part number 202003P1 will have "(NHA 202003-1)" annotated in the two columns. The Numerical Index is compiled in accordance with the numerical filing sequence described in paragraphs 9-16, 9-17 and 9-18.

9-16. Part numbers are arranged beginning from the extreme left-hand position and continue from left to right, one position at a time, until all parts are arranged in sequence by part numbers.

9-17. FIRST POSITION ARRANGEMENT. The order of precedence for the extreme left-hand (first) position of the part number is as follows: letters A through Z, numerals 0 through 9. Alphabetical O's are considered as numerical zeros.

9-18. SECOND AND SUCCEEDING POSITION ARRANGEMENT. The order of precedence in continuing the part number arrangement on the second and succeeding positions of the part number from left to right is as follows:

- Space (blank column)
- Diagonal (slant)
- Point (period)
- Dash (-)
- Letters A through Z
- Numerals 0 through 9

9-19. STOCK NUMBERS.

9-20. The policy of including and updating stock number information in IPB manuals has been discontinued. See USAF Master Cross-Reference Index C-RL-1-AF or Section C0006 of the NAVY Stock List of the Aviation Supply Office for converted part number to stock number information.

9-21. PROVISIONING CODES.

9-22. GENERAL. Provisioning codes assigned by Air Force and Naval Air Systems Command representatives have been applied to the Numerical Index and are shown in the Air Force and Navy Source/Repair/Recoverability Code columns.

9-23. NAVY SOURCE CODES AND DEFINITIONS. Definitions and explanation of source, recoverability and kit codes used in the numerical index of the manual are contained in BUWEPS INSTRUCTION 4423.2.

9-24. AIR FORCE SOURCE CODES AND DEFINITIONS.

9-25. "P" SERIES - PARTS PROCURED AND UNDER INVENTORY STOCK CONTROL:

a. Code "P" identifies parts which may be requisitioned and installed by any level of maintenance consistent with the activity's authorized scope of maintenance. Code "P" is applied to parts on which usage is anticipated or known. Restricted (emergency) service manufacture of code "P" is considered practical but may be accomplished only after confirmation of non-availability from supply sources.

b. Code "PD" identifies parts which may be requisitioned and installed by AF activities authorized depot-level maintenance only. Code "PD" is applied to parts on which usage is anticipated or known. Restricted (emergency) service manufacture of code "PD" is considered practical but may be accomplished only after confirmation of non-availability from supply sources.

c. Code "P1" identifies parts which may be requisitioned and installed by any maintenance level consistent with the activity's authorized

scope of maintenance. Code "P1" is applied to parts on which usage is anticipated or known, and which service manufacture is considered impractical.

d. Code "PID" identifies parts which may be requisitioned and installed by AF activities authorized depot -level maintenance only. Code "PID" is applied to parts on which usage is anticipated or known, and which service manufacture is considered impractical.

e. Code "P2" identifies insurance-type spare parts which can be installed by any AF activity consistent with the activity's authorized scope of maintenance. This code is applied to such parts as are basically structural items if very limited usage, require special tools, templates, and/or jigs, and are very difficult, impractical, or uneconomical to manufacture by AF activities. These items are not subject to periodic replacement or wearout but may require infrequent replacement as a result of accidents or other unexpected occurrences. Delayed procurement items are included under this code.

f. Code "P2D" identifies insurance-type parts which may be installed by AF activities which are authorized depot -level maintenance only. This code is applied to parts as described under code "P2" and to delayed procurement items.

9-26. "M" SERIES - MANUFACTURE, PARTS NOT PROCURED:

a. Code "M" identifies parts, the manufacture and installation of which are within the capabilities of field maintenance activities; and to which all of the following conditions apply:

1. Procurement is not justified because of low usage or peculiar storage and installation factors. Needs are to be met by local manufacture only as required.

2. Their manufacture does not require tools, equipment or skills not normally authorized at field maintenance level.

3. Does not require test equipment not normally authorized at field maintenance level.

4. Does not require material not normally available in AF inventory.

b. Code "M1" identifies parts which can be manufactured at activities authorized depot-level maintenance facilities and to which all of the following conditions apply:

1. Procurement is not justified because of low usage or peculiar storage and installation factors. The need of base activities are to be met by requisitioning from the geographical AMA, SSM, AMA or IM AMA.

2. Their manufacture is beyond capabilities of field maintenance activities as outlined above.

3. Their manufacture does not require tools or equipment not normally authorized at all AMAs.

9-27. "A" SERIES - ASSEMBLE, ASSEMBLE NOT PROCURED:

a. Code "A" identifies items capable of being assembled at any level of maintenance and is applied to assemblies of two or more parts, the majority of which are purchased and/or service manufactured.

b. Code "AI" identifies assemblies which can be assembled at AF activities authorized, depot -level maintenance only and is applied to assemblies described under "A" code.

9-28. "X" SERIES - PARTS CONSIDERED IMPRACTICAL FOR SERVICE MANUFACTURE:

a. Code "X" is applied to main structural members or similar parts, which, if required, would suggest extensive repair. The need for a part or parts coded "X" (wing spars, center section structure, etc.) should normally result in a recommendation to retire the article from service.

b. Code "XI" identifies parts applicable at any level of maintenance consistent with the activity's authorized scope of maintenance and for which it is more feasible to obtain the next higher assembly; for example, an integral detail part such as a welded segment inseparable from its assembly; a part machined in a matched set; or a part of any assembly which, if required, would suggest extensive reconditioning of such assembly. In some cases, code "XI" may be used to indicate an integral detail part of an assembly which has no anticipated usage and as an assembly was source-coded "M" or "MI".

c. Code "X1D" identifies parts which are described under the "X1" code but which are applicable to AF activities authorized depot-level maintenance only.

d. Code "X2" identifies parts which are applicable to any level of maintenance consistent with the activity's authorized scope of maintenance, for which there is no anticipated usage, and which are impractical for service manufacture. This type of item will not be stocked. Such parts shall be obtained from reclamation or, if not available from this source, requisitioned through normal supply channels together with supporting justification for one-time procurement and immediate use. Repeated requests shall justify a change to a code "Pi" or "P2" as applicable, if considered economical to procure and store such parts.

e. Code "X2D" identifies parts which are described under the "X2" code but which are applicable to AF activities authorized depot-level maintenance only. Repeated requests for such parts shall justify a change to a "P1D" or "P2D" code, as applicable, if considered economical and feasible to procure and stock such parts.

9-29. CODE "U" - PARTS NOT PROCURED, MANUFACTURED, OR STOCKED. Code "U" is applied to installation drawings, diagrams, instruction sheets, field-service drawing numbers, and parts not otherwise of supply significance, including obsolete parts, which cannot be procured or service manufactured.

9-30. MAINTENANCE REPAIR LEVEL CODES. The following are the maintenance repair level codes and their definitions:

a. CODE "S" - NO REPAIR. Code "S" identifies items which are nonreparable and have no reclamation value. When these items fail they will be disposed of at user level as condemned material.

b. CODE "B" - NO REPAIR: RECONDITION. Code "B" identifies assemblies or parts that will be reconditioned at the user level by adjusting, cleaning, soldering broken connection, etc. If these items cannot be returned to serviceable condition by such means they will be disposed of at user level as condemned material. No repair parts or tools are specially procured for maintenance of these items.

c. CODE "F" - REPAIR AT FIELD LEVEL. Code "F" identifies items which will be repaired by the field level maintenance activities. Normal servicing will be done by organizational level maintenance. Selected parts, tools and technical order data are procured and provided to applicable field level maintenance activities for repair of these items. No SRA is established for these items. If the condition of these items is such that they cannot be returned to serviceable condition by the field level maintenance activity with authorized parts and tools, they will be disposed of as condemned material. If repair of "F" coded items cannot be accomplished due to unavailability of authorized parts, tools or other capability, the applicable SSM/IM will be so advised with request for disposition instructions. "F" coded Hi-Valu or Critical Items, regardless of condition, will be turned into supply for disposition instructions from the applicable SSM/IM.

d. CODE "D" - LIMITED FIELD REPAIR: DEPOT OVERHAUL. Code "D" identifies items on which a limited degree of repair can be accomplished by field level maintenance activities. Normal servicing will be done at organizational level. SRA is established for overhaul of these items. A range of repair parts, tools, and technical order data consistent with the capability of repair are procured and provided to applicable field maintenance activities. Because of the design characteristics and complexity of repair, the degree of repair which is authorized on these items at the field maintenance level is necessarily determined by the degree of technical skills required and the cost of special tools, special test equipment, spare parts, and the predicted frequency of failure generation. If these items cannot be returned to serviceable condition with authorized parts and tools they will be returned to supply for shipment to the designated SRA.

e. CODE "DM" - LIMITED FIELD REPAIR: MOBILE DEPOT OVERHAUL. Code "DM" identifies items to which all the conditions of code "D" apply except that repair beyond field capability will be done by the mobile depot activity (MDA). If the MDA cannot repair these items, they will determine whether these items should be condemned or sent to the SRA.

f. CODE "L" - DEPOT LEVEL MAINTENANCE ONLY. Code "L" identifies items that will be repaired only at designated SRA.

T.O. 33A1-8-468-11
TM 11-6625-1711-15-1
NAVAIR 16-30APM245-2

Repair parts and tools for repair are procured and provided only to these authorized activities. Required functional checkout and bench check equipment may be provided to applicable organizational and field level maintenance activities for accomplishing external adjustment or calibration and for verifying serviceability of these items. If they are found unserviceable they will be turned into supply for shipment to the SRA.

g. CODE "LM" -DEPOT LEVEL MAINTENANCE ONLY; MOBILE DEPOT ACTIVITY. Code "LM" identifies items to which all conditions of Code "L" apply except that repair will be accomplished by MDA. If MDA cannot

repair these items, they will determine whether these items should be condemned or sent to the SRA.

9-31. REFERENCE DESIGNATION INDEX.

9-32. The Reference Designation Index includes reference designations for all electrical parts shown on schematic and wiring diagrams. The list is arranged in alphanumerical sequence by reference designation numbers and includes figure and index numbers and part numbers.

9-33. T. C. T. O. COMPLIANCE. There are no Time Compliance Technical Orders applicable to this publication.

HOW TO USE THE ILLUSTRATED PARTS BREAKDOWN

The illustration shows a complex mechanical assembly with six numbered callouts (1-6) pointing to different parts of the breakdown process:

- 1:** Points to the Reference Designation Index table.
- 2:** Points to the Numerical Index table.
- 3:** Points to the pictorial representation of the assembly.
- 4:** Points to the Reference Designation Index table.
- 5:** Points to the Numerical Index table.
- 6:** Points to the pictorial representation of the assembly.

The Reference Designation Index table includes columns for Reference Designation, Figure No., Part Number, and Part Name. The Numerical Index table includes columns for Part No., Part Name, and Figure No. The pictorial representation shows a detailed view of the assembly with various components labeled with numbers.

WHEN THE PART NUMBER OR REFERENCE DESIGNATION IS KNOWN

1. When the part number is known, refer to the Numerical Index (pages 9-23 thru 9-25). Locate the part number and note the figure and index number assigned to the part number.
2. Turn to the figure number indicated and locate the Index number referenced in the Numerical Index.
3. If a pictorial representation of the part, or its location is desired, refer to the same index number on the accompanying illustration.

4. When the reference designation is known refer to the Reference Designation Index (pages 9-26, 9-27), Locate the reference designation and note the figure and index number and the part number assigned.

5. Turn to the figure indicated and locate the index number referenced in the Reference Designation Index.

6. If a pictorial representation of the part, or its location is desired, refer to the same index number on the accompanying illustration.

HOW TO USE THE ILLUSTRATED PARTS BREAKDOWN

T.O. 33A1-8-468-11
 TM 11-4823-1711-15-1
 NAVAIR 16-30APM245-2

T.O. 33A1-8-468-11
 TM 11-4823-1711-15-1
 NAVAIR 16-30APM245-2

LIST OF ILLUSTRATIONS

Number	Title	Page	Number	Title	Page
3-1	Simulator Test Set	vi	7-4	Mode 4 Tests, Test Setup	7-8
3-1	AN/APM-245A	vi	8-1	Simulator Test Set, Logic	8-3
3-1	Dimensional Drawing	3-2		Diagram, Schematic	
3-2	Simulator Test Set, External	3-3	8-2	Simulator Test Set, Power	8-5
	Connections			Supply Circuits, Schematic	
4-1	Test Word, Auxiliary Pulse,	4-3	8-3	Integrated Circuits, Logic	8-6
	Markers Generator Circuits,			Diagram Equivalents	
4-2	Logic Block Diagram	4-3	8-4	Simulator Test Set, Wave-	8-8
	Pulse Generator Circuits,			forms	
4-3	Logic Block Diagram	4-9	9-1	Simulator Test Set	9-9
	AN/APM-245A				
4-3	Simulator Test Set, Controls,	4-13	9-2	Test Set	9-10
	Indicators, and Connectors,			AN/APM-245A	
8-1	Logic Troubleshooting Flow	8-5	9-3	Test Set Front Panel	9-14
	Chart		9-4	Logic Assembly	9-16
7-1	Internal Trigger Tests,	7-3	9-5	Power Supply Assembly	9-20
	Test Setup		9-6	Power Cable Assembly	9-21
7-2	External Trigger via Internal	7-5	9-7	BNC Video Coax Cable	9-22
	Trigger Jitter Test, Test			Assembly	
7-3	Test Word Output Tests,	7-7			
	Test Setups				

LIST OF TABLES

Number	Title	Page
1-1	Leading Particulars	3-9
1-2	Equipment Supplied	3-9
2-1	Special Tools and Test Equipment List	3-11
3-1	Simulator Test Set, Controls and Indicators	4-11
4-2	Simulator Test Set, Input and Output Connectors	4-14
4-3	Preventive Maintenance Checks and Services, Daily Schedule (Operator Maintenance Category)	5-3
5-3	Preventive Maintenance Checks and Services, Weekly Schedule (Operator Maintenance Category)	5-3
5-3	Preventive Maintenance Checks and Services, Monthly Schedule (Organizational Maintenance Category)	5-4
7-1	Test Facilities Required	7-1

INDEX NO	PART NO	DESCRIPTION	QTY	UNIT	ASSEMBLY OR CODE
9-4	12167-1	FRONT PANEL, Test set (Control of unit number 2020271)			
	12170	PLATE, Identification			
	122018-1	SWITCH			
	12188-2	SWITCH, Pushbutton (27182)			
	18-486	FACEPLATE, Mounting (27182)			
	107-99	LOCATING SCREW, Metric plated brass (27182)			
	141197-118	METER (27182) (Mounting with screw)			
	141197-119	METER (25381) (Mounting with screw)			
	141197-120	SCREEN			
	141197-121	WASHER			
	141197-122	NUT			
	141197-123	TERMINAL, Dup ST 20064-1 (Mounting with screw)			
	141197-124	SWITCH			
	141197-125	LEAD			
	141197-126	LAMP, Glow (27182) (Mounting with screw)			
	141197-127	LIGHT, Indicator (27182) (Mounting with screw)			
	141197-128	FILTER, 20064-1 (Mounting with screw)			
	141197-129	CONNECTOR			
	141197-130	WASHER			
	141197-131	NUT			
	141197-132	TERMINAL, Dup ST 20064-1 (Mounting with screw)			

WHEN THE PART NUMBER IS NOT KNOWN

1. Determine the function and application of the part required. Turn to the List of Illustrations for Section IX and select the most appropriate title. Note the illustration page number.

2. Turn to the page indicated and locate the desired part on the illustration.

3. From the illustration, obtain the index number assigned to the part desired, Refer to the accompanying description for specific information regarding the part.

9-8

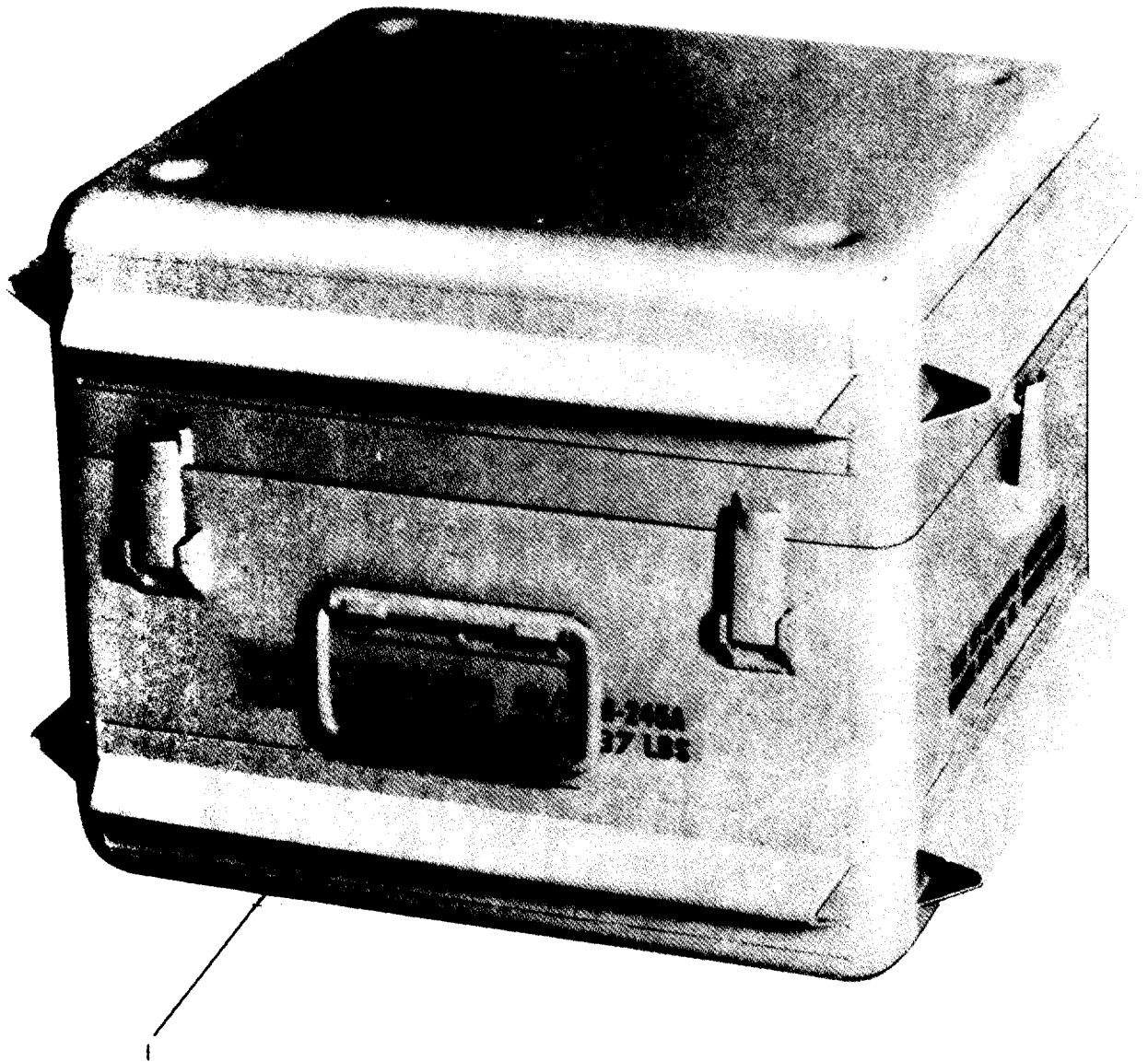

Figure 9-1. Simulator Test Set AN/APM-245A

INDEX NO.

DESCRIPTION

FIGURE NO.

1

SIMULATOR TEST SET AN/APM-245A

9-2

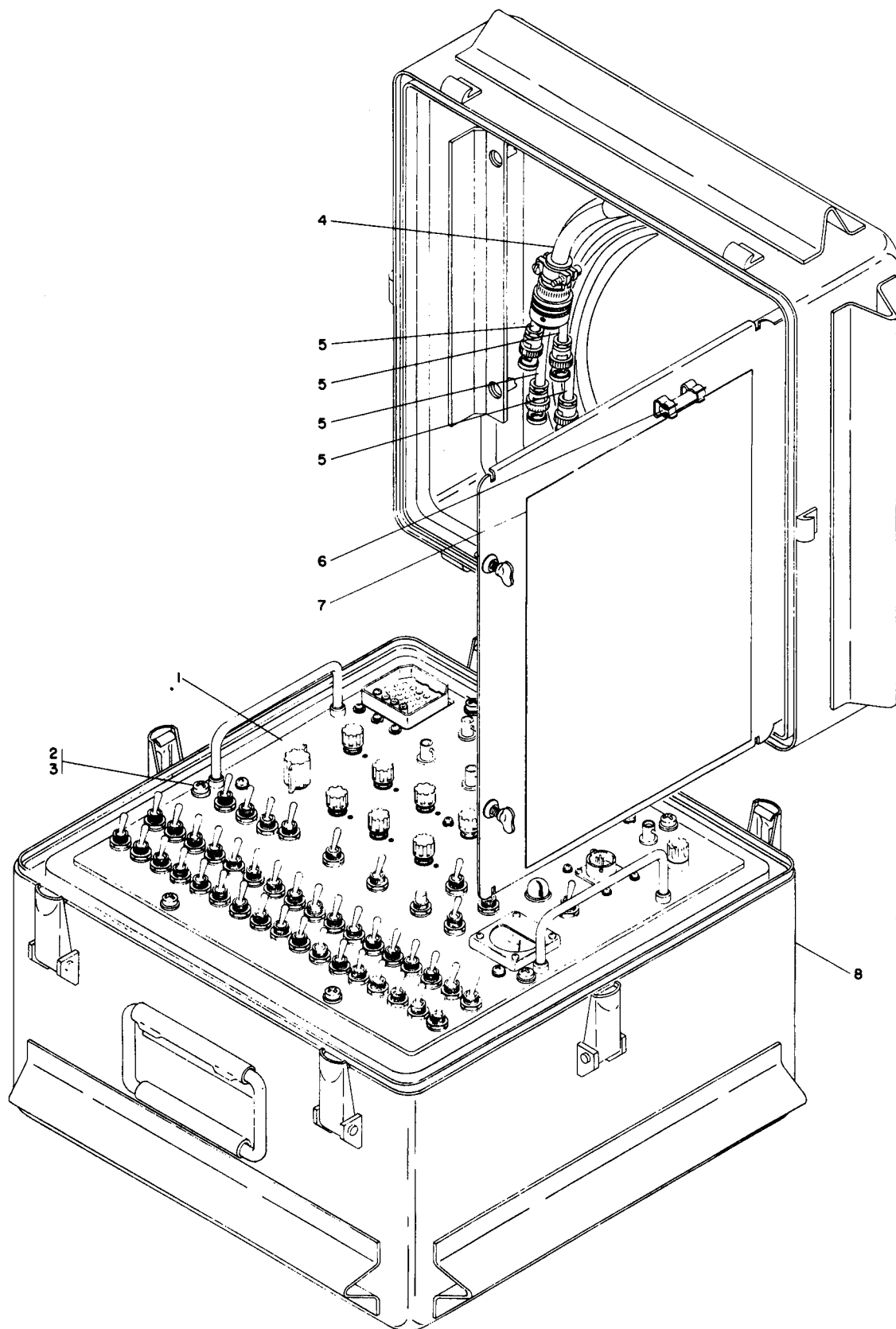

Figure 9-2. Simulator Test Set AN/APM-245A

FIG & NDEX NO.	PART NO.	DESCRIPTION							UNITS PER ASSY.	USABLE ON CODE	
		1	2	3	4	5	6	7			
)-2-	121984-1	TEST SET, Simulator AN/APM-245A (See fig. 9-1 for complete assembly)							1		
	-1	121986-1	TEST SET (See fig. 9-3 for detail breakdown) (ATTACHING PARTS)							1	
	-2	MS51958-64	. SCREW							6	
	-3	AN960C10	. WASHER ---*---							6	
	-4	117740	CABLE ASSEMBLY, Power (See fig. 9-7 for detail breakdown)							1	
	-5	117743	CABLE ASSEMBLY, BNC video coax (See fig. 9-8 for detail breakdown)							4	
	-6	FM03-1/2A	. FUSE							1	
	-7	650820	. PLATE, Instruction							1	
-8	79W17	. CASE, Combination (19178) (Hazeltine Spec Cont Dwg 360401)							1		
)-3-	121986-1	TEST SET (See fig. 9-2 for NHA)							REF		
	-1	121987-1	FRONT PANEL, Test set (See fig. 9-4 for detail breakdown) . (ATTACHING PARTS)							1	
	-2	MS51958-63B	. SCREW							4	
	-3	AN960XC10	. WASHER ---*---							4	
	-4	121979-1	LOGIC ASSEMBLY (See fig. 9-5 for detail breakdown) (ATTACHING PARTS)							1	
	-5	MS51957-27	. SCREW							6	
	-6	MS35338-136	. WASHER							6	
	-7	AN960C6	. WASHER ---*---							6	
	-8	121980-1	POWER SUPPLY ASSEMBLY (See fig. 9-6 for detail breakdown) (ATTACHING PARTS)							1	
	-9	MS51957-27	. SCREW							5	
	-10	MS35338-136	. WASHER							5	
	-11	AN960C6	. WASHER ---*---							5	
	-12	522469	BRACKET, Transformer (ATTACHING PARTS)							1	
	-13	MS51957-45	. SCREW							2	
	-14	AN960C8	. WASHER ---*---							2	
	-15	890578	TRANSFORMER (ATTACHING PARTS)							1	
	-16	MS51957-30	. SCREW							2	
	-17	AN960C6	. WASHER							2	
	-18	RM52LHA4972-5-62	. NUT-CLIP, Floating (72982) (Hazeltine Spec Cont Dwg 660092) ---*---							2	
	-19	147-4-032BRASSHT	. TERMINAL, Lug (79963) (Hazeltine Spec Cont. Dwg ST850064-1) (ATTACHING PARTS)							1	
	-20	MS51957-14	. SCREW							1	
	-21	MS21044C04	. NUT ---*---							1	
	-22	SE26-1	. TERMINAL (ATTACHING PARTS)							1	
	-23	MS51957-47	. SCREW							1	
	-24	MS21044C08	. NUT ---*---							1	
	-25	280060	CAM (ATTACHING PARTS)							1	
	-26	810327	. SCREW, Hex slotted head							1	
	-27	AN960C10L	. WASHER ---*---							1	
-28		DELETED									

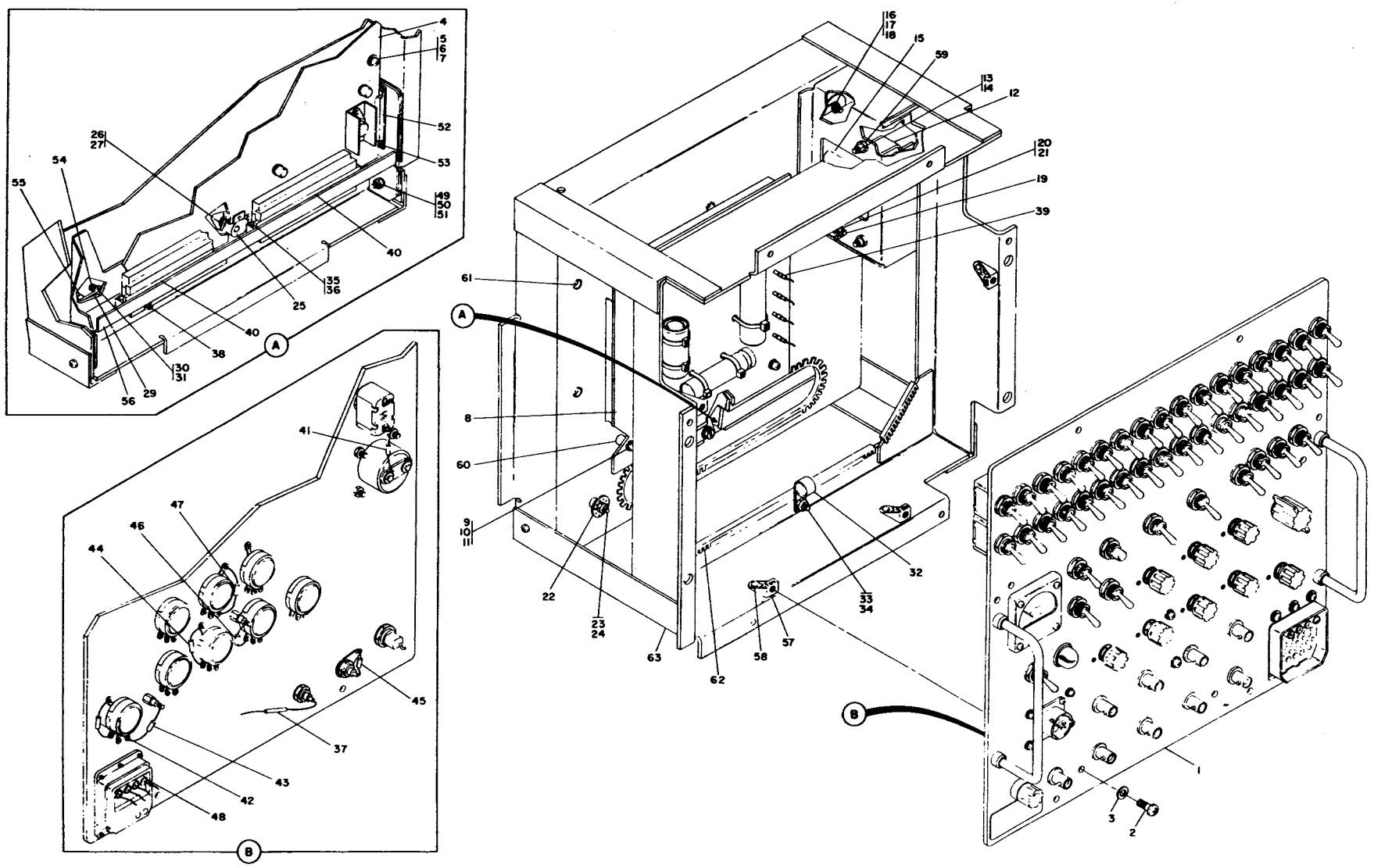

Figure 9-3. Test Set

FIG & IDEX NO.	PART NO.	DESCRIPTION							UNITS PER ASSY.	USABLE ON CODE
		1	2	3	4	5	6	7		
-3-29	522470	LOCK, Card rack							1	
		(ATTACHING PARTS)								
-30	MS21044C06	. NUT							1	
-31	AN960C6	. WASHER							1	
		---*---								
-32	HP-7N	CLAMP, Loop, plastic (09922) (Hazeltine Spec Cont							1	
		Dwg ST310002-7)								
		(ATTACHING PARTS)								
-33	MS51957-45	. SCREW							1	
-34	MS21044C08	. NUT							1	
		---*---								
-3-	963635	WIRING HARNESS							1	
		(ATTACHING PARTS)								
-35	MS51957-17	SCREW							4	
-36	MS21044C04	NUT							4	
		---*---								
-3-	963635-01	. . WIRING HARNESS							1	
-37	D100	. . . SOLDER SLEEVE (08795) (Hazeltine Spec							16	
		Cont Dwg 310100-1)								
-38	66009-2	. . . CONTACT, Electrical (00779) (Hazeltine Spec							70	
		Cont Dwg 331058)								
-39	60804-1	. . . RECEPTACLE, Wire (00779) (Hazeltine Spec							6	
		Cont Dwg 331080)								
-40	3-582151-4	. . . CONNECTOR, Receptacle, electrical							2	
		(00779) (Hazeltine Spec Cont Dwg 350573-40)								
-3-	963635-99	. . WIRING HARNESS							1	
-41	RCR20G471JS	. . . RESISTOR							1	
-42	RCR07G274JS	. . . RESISTOR							1	
-43	RCR07G393JS	. . . RESISTOR							1	
-44	RCR07G752JS	. . . RESISTOR							1	
-45	RCR07G910JS	. . . RESISTOR							1	
-46	RCR07G102JS	. . . RESISTOR							1	
-47	RCR07G471JS	. . . RESISTOR							1	
-48	94-620	. . . PIN, Coax (02660) (Hazeltine Spec Cont							4	
		Dwg 350886-6)								
-3-	202003-1	. CARD GATE							1	
		(ATTACHING PARTS)								
-49	MS51957-31	. SCREW							2	
-50	750371	. BUSHING							2	
-51	MS21044C06	. NUT							2	
		---*---								
-52	35-1S2-4-3	. . HOLDER, P.C. board (18915) (Hazeltine Spec							2	
		Cont Dwg 341070)								
		(ATTACHING PARTS)								
-53	MS16535-13	. . RIVET							4	
		---*---								
-54	NCS6-2-12	. . STUD, Self clinching (42498)							1	
		(Hazeltine Spec Cont Dwg 750376-6-2-12)								
-55	MS20470AD4-4	. . RIVET							1	
-56	No Number	. . CARD GATE (Consists of part number 202003P1							1	
		and 202003P2)								
-3-	202001-1	. CHASSIS, Test set							1	
-57	MF6001-3	. . NUT-ANCHOR, Right angle (75237) (Hazeltine							4	
		Spec Cont Dwg 660136-4)								
		(ATTACHING PARTS)								
-58	MS20470AD3-4	. . RIVET							8	
		---*---								
-59	LKS832-2	. . NUT, Self-clinching, self-locking (46384)							2	
		(Hazeltine Spec Cont Dwg ST660114-6)								
-60	9556CSS0632-7	. . STANDOFF, Threaded (06540) (Hazeltine							5	
		Spec Cont Dwg 660091-1)								
-61	9562CSS0632-7	. . STANDOFF, Threaded (06540) (Hazeltine							6	
		Spec Cont Dwg 660091-2)								
-62	MS21266-2N	. . GROMMET							23 in.	

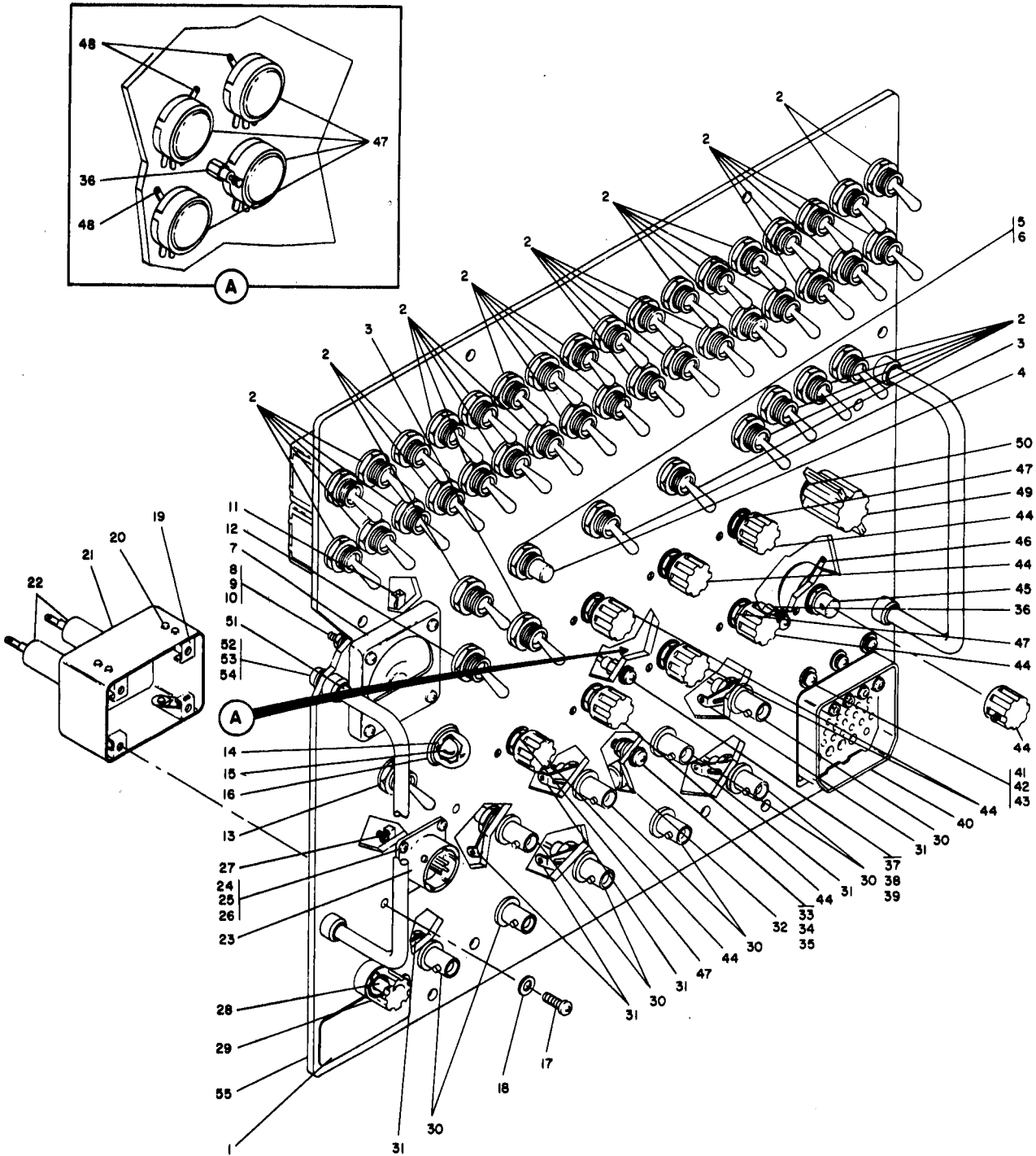

Figure 9-4. Test Set Front Panel

FIG & INDEX NO.	PART NO.	DESCRIPTION							UNITS PER ASSY.	USABLE ON CODE
		1	2	3	4	5	6	7		
9-3-63	No Number	.	.	CHASSIS, Test set (Consists of part numbers 202001P1.. through 202001P8)					1	
9-4-	121987-1	FRONT PANEL, Test set (See fig. 9-3 for NHA)							REF	
-1	651705	.	.	PLATE, Identification					1	
-2	MS35058-23	.	.	SWITCH					40	
-3	MS35058-21	.	.	SWITCH					2	
-4	8411K12	.	.	SWITCH, Pushbutton (27193) (Hazeltine Spec Cont Dwg 841149) (ATTACHING PARTS)					1	
-5	15-966-2	.	.	FACENUT, Hexagon, nickle plated brass (27193) (supplied with switch)					1	
-6	16-886	.	.	LOCKWASHER, Internal tooth, cadmium plated steel (27193) (supplied with switch)					1	
-7	907-99	---*---								
-7	907-99	.	.	METER (25936) (Hazeltine Spec Cont Dwg 610049) (ATTACHING PARTS)					1	
-8	MS51957-19B	.	.	SCREW					4	
-9	MS35338-135	.	.	WASHER					4	
-10	MS35649-244	.	.	NUT					4	
-11	147-4-032BRASSHT	---*---								
-11	147-4-032BRASSHT	.	.	TERMINAL, Lug (79963) (Hazeltine Spec Cont Dwg ST850064-1)					1	
-12	MS35058-29	.	.	SWITCH					1	
-13	MS35059-22	.	.	SWITCH					1	
-14	95-0935	.	.	LENS, Indicator light (72619) (Hazeltine Spec Cont Dwg 341068)					1	
-15	NE51H	.	.	LAMP, Glow (71744) (Hazeltine Spec Cont Dwg 250130-3)					1	
-16	95-0463-09-211	.	.	LIGHT, Indicator (72619) (Hazeltine Spec Cont Dwg 250045)					1	
9-4-	121985-1	.	.	FILTER BOX (ATTACHING PARTS)					1	
-17	MS51957-15B	.	.	SCREW					4	
-18	AN960XC4	.	.	WASHER					4	
-19	MF6001-04	---*---								
-19	MF6001-04	.	.	NUT-ANCHOR, Right angle (75237) (Hazeltine Spec Cont Dwg 660136-1) (ATTACHING PARTS)					4	
-20	MS20470AD3-3	.	.	RIVET					8	
-21	HU640513/16ST	---*---								
-21	HU640513/16ST	.	.	CASE, Rectangular (02875) (Hazeltine Spec Cont Dwg 360400)					1	
-22	2JX83	.	.	FILTER, Radio interference (56289) (Hazeltine Spec Cont Dwg 690060)					2	
-23	MS3112E14-5P	.	.	CONNECTOR (ATTACHING PARTS)					1	
-24	MS51957-16B	.	.	SCREW					4	
-25	MS35338-135	.	.	WASHER					4	
-26	MS35649-244	.	.	NUT					4	
-27	147-4-032BRASSHT	---*---								
-27	147-4-032BRASSHT	.	.	TERMINAL, Lug (79963) (Hazeltine Spec Cont Dwg ST850064-1)					1	
-28	FM03-1/2A	.	.	FUSE					1	
-29	342015L	.	.	FUSEHOLDER, (Non-indicating) (36555) (Hazeltine Spec Cont Dwg 430058)					1	
-30	UG-1094A/U	.	.	CONNECTOR					9	
-31	639	.	.	TERMINAL, Lug (79963) (Hazeltine Spec Cont Dwg 850112)					6	
-32	HP-7N	.	.	CLAMP, Loop, plastic (09922) (Hazeltine Spec Cont Dwg ST310002-7)					1	

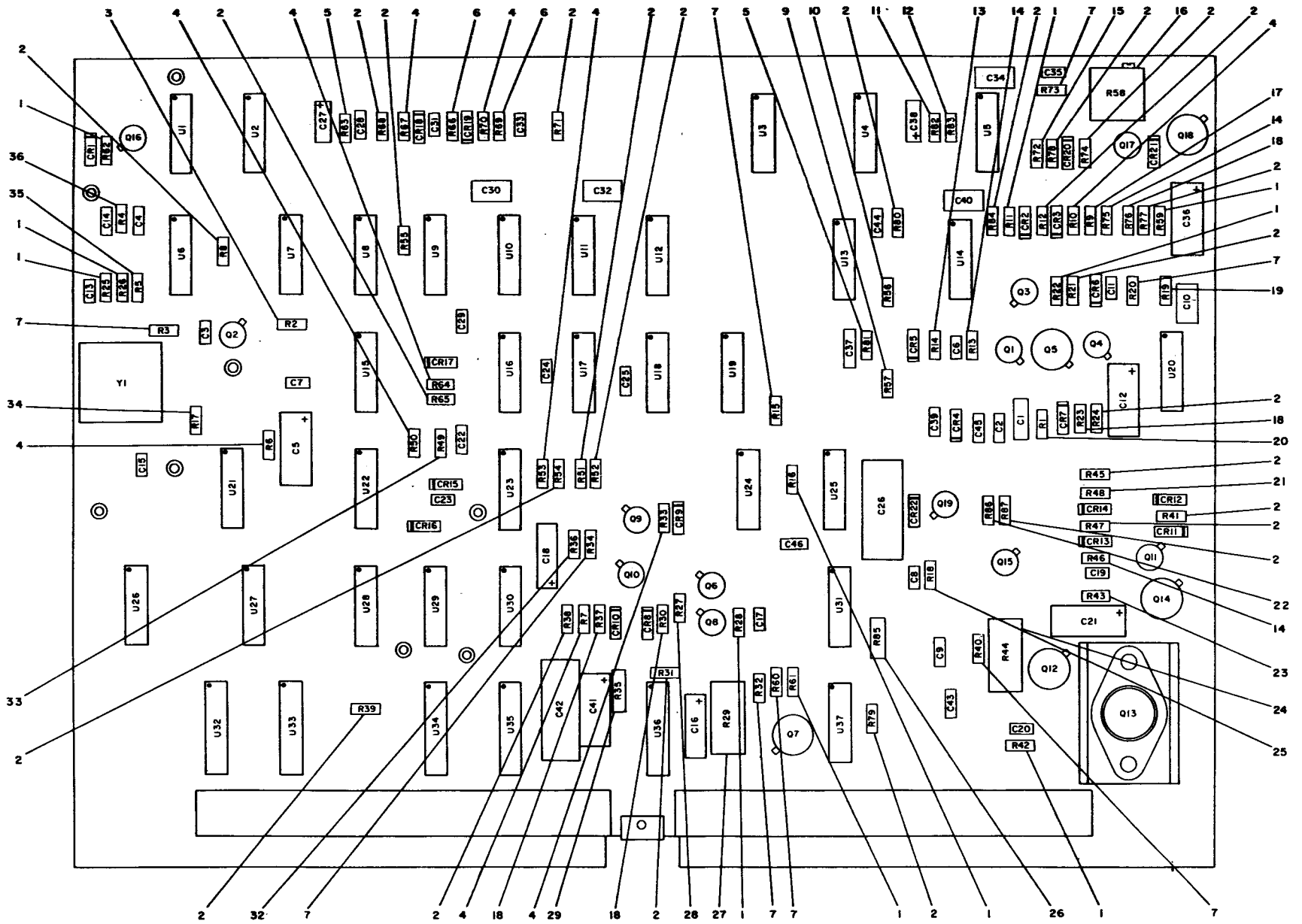

Figure 9-5. Logic Assembly (Sheet 1 of 2)

FIG & INDEX NO.	PART NO.	1	2	3	4	5	6	7	DESCRIPTION	UNITS PER ASSY.	USABLE ON CODE
-4-									(ATTACHING PARTS)		
-33	MS51957-46B	.							SCREW	1	
-34	AN960XC6	.							WASHER	1	
-35	MS21044C08	.							NUT	1	
									---*---		
-36	SE109D02	.							TERMINAL	2	
									(ATTACHING PARTS)		
-37	MS51957-27B	.							SCREW	2	
-38	MS35338-136B	.							WASHER	2	
-39	AN960XC6	.							WASHER	2	
									---*---		
-40	94-62548-33								CONNECTOR, Receptacle, electrical (02660)	1	
									(Hazeltine Spec Cont Dwg 350886-5)		
									(ATTACHING PARTS)		
-41	MS51957 -16B	.							SCREW	6	
-42	MS35338-135B	.							WASHER	6	
-43	AN960XC4	.							WASHER	6	
									---*---		
-44	S-775-3								KNOB, Control (75376) (Hazeltine Spec Cont	8	
									Dwg 620247)		
-45	JA1N040P504UA								RESISTOR, Variable, composition (01121)	1	
									(Hazeltine Spec Cont Dwg 730605)		
-46	761								TERMINAL, Lug (79963) (Hazeltine Spec Cont	1	
									Dwg 850826)		
-47	JA1N040P103UA	.							RESISTOR, Variable, composition (01121)	7	
									(Hazeltine Spec Cont Dwg 730604)		
-48	761	.							TERMINAL, Lug (79963) (Hazeltine Spec Cont	3	
									Dwg 850826)		
-49	S-750-3L-BB								KNOB, Control (75376) (Hazeltine Spec Cont	1	
									Dwg 620248)		
-50	841148-2								SWITCH, Rotary	1	
-51	10353-A-0832								HANDLE, Round (06540) (Hazeltine Spec Cont	2	
									Dwg 410033)		
									(ATTACHING PARTS)		
-52	MS51957-45	.							SCREW	4	
-53	MS35338-137	.							WASHER	4	
-54	16022-A-2	.							FERRULE (06540) (Hazeltine Spec Cont Dwg 341069)	4	
									---*---		
-55	522468	.							PANEL, Front, test set	1	
-5-	121979-1								LOGIC ASSEMBLY (See fig. 9-3 for NHA)	REF	
-1	RCR07G102JM	.							RESISTOR.	10	
-2	RCR07G103JM	.							RESISTOR.	24	
-3	RCR07G151JM	.							RESISTOR.	1	
-4	RCR07G472JM	.							RESISTOR.	9	
-5	RCR07G273JM	.							RESISTOR.	2	
-6	RN55D2742F	.							RESISTOR.	2	
-7	RCR07G101JM	.							RESISTOR.	8	
-8									DELETED		
-9	RN55D2051F	.							RESISTOR.	1	
-10	RN55D1692F	.							RESISTOR.	1	
-11	RCR07G393JM	.							RESISTOR.	1	
-12	RCR07G752JM	.							RESISTOR.	1	
-13	RCR07G332JM	.							RESISTOR.	1	
-14	RCR07G222JM	.							RESISTOR.	3	
-15	RN55D5621F	.							RESISTOR.	1	
-16	RT22C2P502	.							RESISTOR.	1	
-17	RCR07G750JM	.							RESISTOR.	1	
-18	RCR07G100JM	.							RESISTOR.	4	
-19	RN55D6191F	.							RESISTOR.	1	
-20	RN55D8252F	.							RESISTOR.	1	
-21	RCR07G431JM	.							RESISTOR.	1	
-22	RCR07G5R1JM	.							RESISTOR.	1	

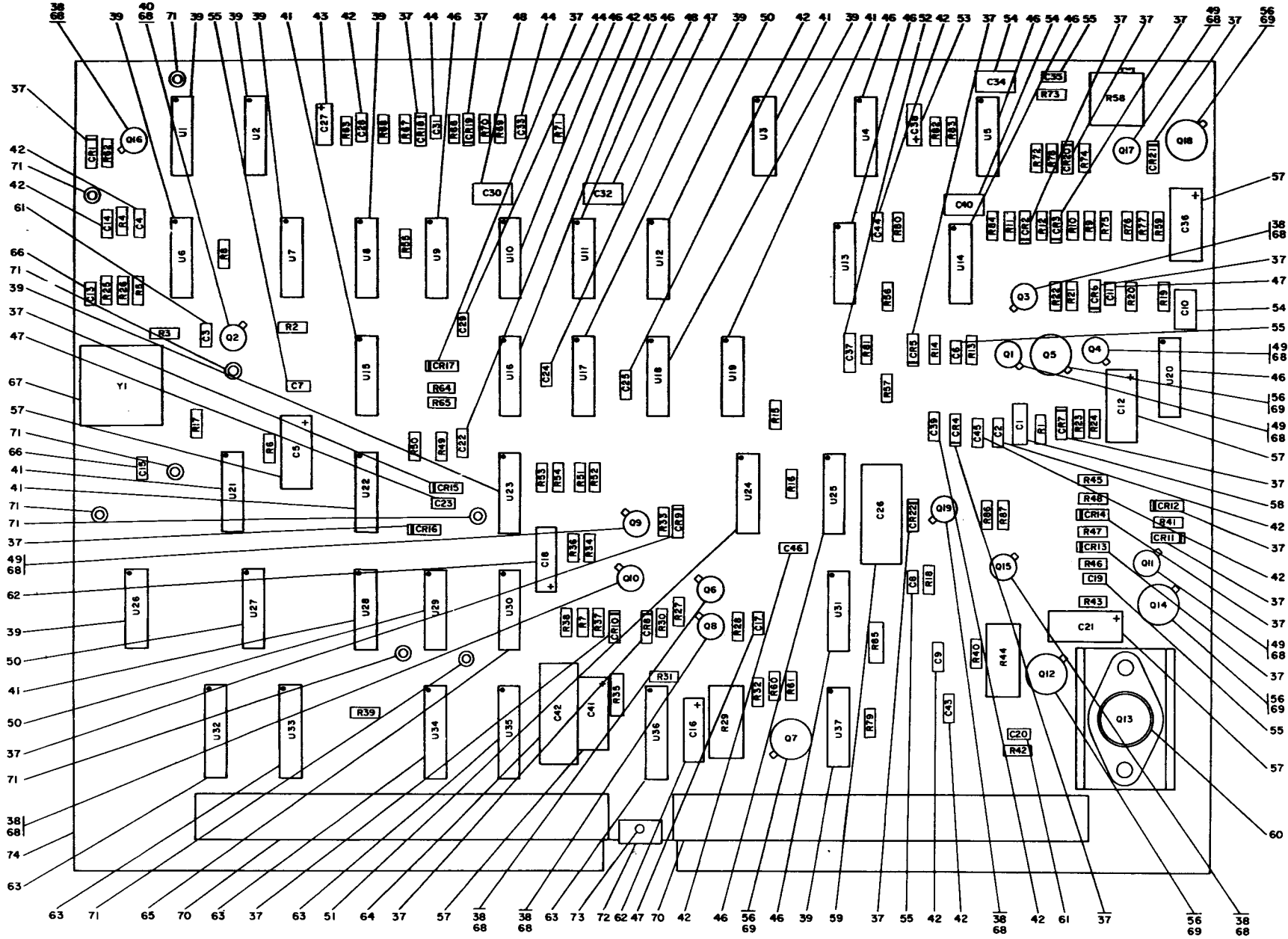

Figure 9-5. Logic Assembly (Sheet 2 of 2)

FIG & INDEX NO.	PART NO.	DESCRIPTION							UNITS PER ASSY.	USABLE ON CODE
		1	2	3	4	5	6	7		
-5-23	RCR07G180JM								1	
-24	RC42GF180J								1	
-25	RCR07G223JM								1	
-26	RCR20G301JM								1	
-27	RC42GF332J								1	
-28	RCR07G681JM								1	
-29	RCR20G512JM								1	
-30										
-31										
-32	RCR07G152JM								1	
-33	RCR07G184JM								1	
-34	RCR07G622JM								1	
-35	RCR07G471JM								1	
-36	RCR07G470JM								1	
-37	JAN1N914								22	
-38	JAN2N2222								7	
-39	MC7400P								10	
-40	2N4852								1	
-41	MC7473P								6	
-42	CK13BX103K								12	
-43	M39003/01-2092								1	
-44	CK12BX101K								3	
-45	MC7410P								1	
-46	MC74121P								10	
-47	CK12BX471K								4	
-48	CM10ED820FP3								2	
-49	JAN2N2907A								5	
-50	MC7420P								3	
-51	MC7405P								1	
-52	K472FK50J								1	
-53	M39003/01-2094								1	
-54	CM10FD101FP3								3	
-55	CK12BX102K								5	
-56	JAN2N2219A								5	
-57	M39003/01-2178								5	
-58	CK14BR224K								1	
-59	CP09A1KC223K3								1	
-60	40372								1	
-61	CK12BX222K								2	
-62	M39003/01-2046								2	
-63	MC74151P								5	
-64	CL65CE271MP3								1	
-65	MC7430P								1	
-66	CK12BX221K								2	
-67	EE2A5GSV								1	
-68	7717-18-N								13	
-69	670078								5	
-70	3-582152-9								2	
-71	X1457-2								8	
-72	522471								1	

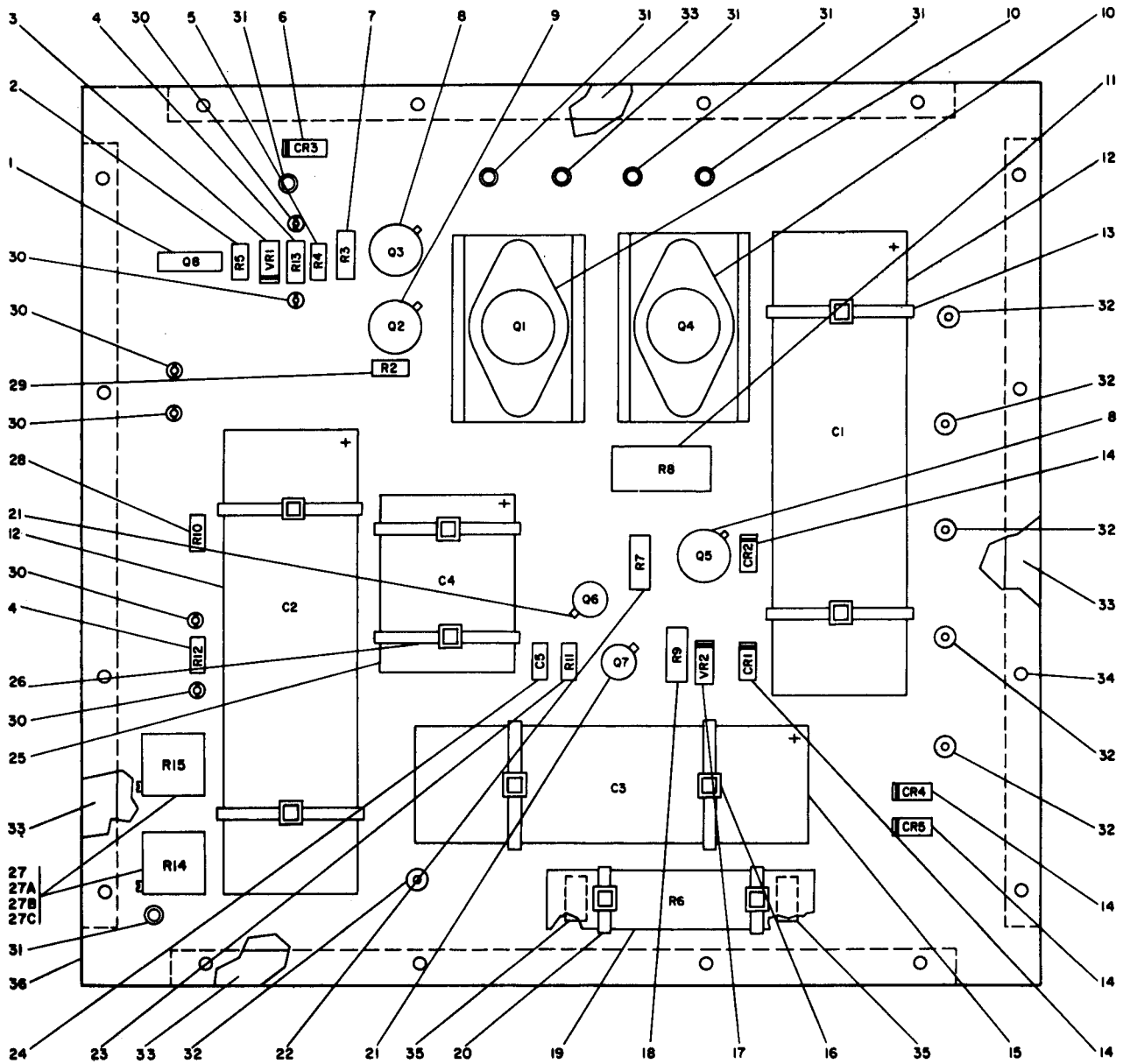

Figure 9-6. Power Supply Assembly

FIG & DEX NO.	PART NO.	1 2 3 4 5 6 7	DESCRIPTION	UNITS PER ASSY.	USABLE ON CODE
5-			(ATTACHING PARTS)		
-73	MS16535-13	.	RIVET	1	
			---*---		
-74	867036	.	PRINTED WIRING BOARD, Logic	1	
6-	121980-1		POWER SUPPLY ASSEMBLY (See fig. 9-3 for NHA)	REF	
-1	MCR106-1	.	RECTIFIER, Silicon controlled (04713) (Hazeltine Spec Cont Dwg 911235)	1	
-2	RCR07G201JM	.	RESISTOR	1	
-3	JAN1N753A	.	SEMICONDUCTOR DEVICE	1	
-4	RCR07G222JM	.	RESISTOR	2	
-5	RCR07G751JM	.	RESISTOR	1	
-6	JAN1N914	.	SEMICONDUCTOR DEVICE	1	
-7	RCR20G622JM	.	RESISTOR	1	
-8	JAN2N2219A	.	TRANSISTOR	2	
-9	40408	.	TRANSISTOR, Power (86684) (Hazeltine Spec Cont Dwg 911237)	1	
-10	40372	.	TRANSISTOR, NPN (86684) (Hazeltine Spec Cont Dwg 911233)	2	
-11	RC42GF562J	.	RESISTOR	1	
-12	39D317F150HS4	.	CAPACITOR, Fixed, electrolytic, 310 uf, 150 Vdcw (56289) (Hazeltine Spec Cont Dwg 270626-1)	2	
			(ATTACHING PARTS)		
-13	MS18034-5NN	.	STRAP	4	
			---*---		
-14	JAN1N3611	.	SEMICONDUCTOR DEVICE	4	
-15	39D258G015GP4	.	CAPACITOR, Fixed, electrolytic, 2500 uf, 15 Vdcw (56289) (Hazeltine Spec Cont Dwg 270626-2)	1	
			(ATTACHING PARTS)		
-16	MS18034-5NN	.	STRAP	2	
			---*---		
-17	JAN1N746A	.	SEMICONDUCTOR DEVICE	1	
-18	RCR20G151JM	.	RESISTOR	1	
-19	RW68V6R8	.	RESISTOR	1	
			(ATTACHING PARTS)		
-20	MS18034-5NN	.	STRAP	2	
			---*---		
-21	JAN2N2222	.	TRANSISTOR	2	
-22	RCR20G101JM	.	RESISTOR	1	
-23	RCR07G152JM	.	RESISTOR	1	
-24	CK13BX103K	.	CAPACITOR	1	
-25	39D128G010HE4	.	CAPACITOR, Fixed, electrolytic, 1200 uf, 10 Vdcw (56289) (Hazeltine Spec Cont Dwg 270626-3)	1	
			(ATTACHING PARTS)		
-26	MS18034-5NN	.	STRAP	2	
			---*---		
-27	RT22C2P103	.	RESISTOR	2	
			(ATTACHING PARTS)		
-27A	NAS1635-00-8	.	SCREW	4	
-27B	MS15795-801	.	WASHER	8	
-27C	MS35650-314	.	NUT	4	
			---*---		
-28	RCR07G561JM	.	RESISTOR	1	
-29	RCR07G103JM	.	RESISTOR	1	
-30	1785-2	.	TERMINAL, Flat flange (71279) (Hazeltine Spec Cont Dwg 850825)	6	
-31	X1457-2	.	TERMINAL, Solder (71279) (Hazeltine Spec Spec Cont Dwg 850041-01)	6	
-32	60599-3	.	PIN, Printed circuit board (00779) (Hazeltine Spec Cont Dwg 331059)	6	
-33	522472	.	STIFFENER, P. C. board	4	
			(ATTACHING PARTS)		
-34	MS16535-12	.	RIVET	16	
			---*---		
-35	681106	.	PAD, Insulator	2	
-36	867037	.	PRINTED WIRING BOARD, Power supply	1	

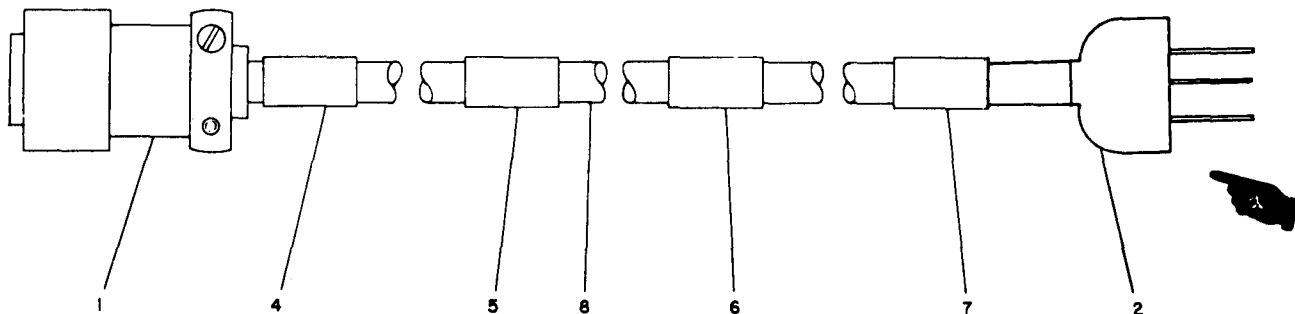

Figure 9-7. Power Cable Assembly

FIG & INDEX NO.	PART NO.	1 2 3 4 5 6 7	DESCRIPTION	UNITS PER ASSY.	USABLE ON CODE
9-7-			CABLE ASSEMBLY, Power (See fig. 9-2 for NHA)	REF	
-1	MS3116F14-5S		. CONNECTOR	1	
-2	41821		. TERMINAL, Lug (00779) (Hazeltine Spec Cont Dwg ST850007-2)	1	
-3	Deleted			1	
-4	ST650716-P1		. SLEEVE, Marker, cable	1	
-5	ST650716-W1		. SLEEVE, Marker, cable	1	
-6	ST650716-117740		. SLEEVE, Marker, cable	1	
-7	ST650716-P2		. SLEEVE, Marker, cable	1	
-8	Deleted				

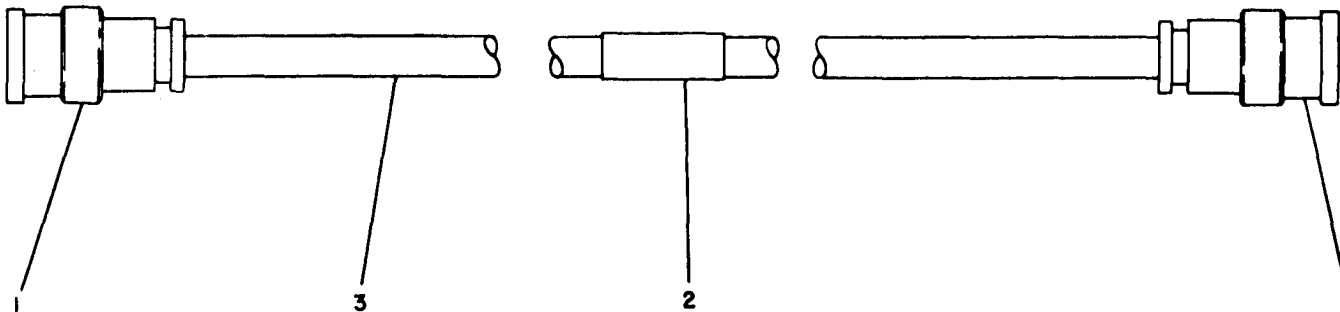

Figure 9-8. BNC Video Coax Cable Assembly

FIG & INDEX NO.	PART NO.	1 2 3 4 5 6 7	DESCRIPTION	UNITS PER ASSY.	USABLE ON CODE
9-8-	117743		CABLE ASSEMBLY, BNC video coax (See fig. 9-2 for NHA)	REF	
-1	UG-260E/U		. CONNECTOR	2	
-2	ST650712-117743		. SLEEVE, Marker, cable	1	
-3	RG-62A/U		. CABLE	49 in.	

Part Number	Figure and Index No.	Qty Per Art	Air Force		Navy		Part Number	Figure and Index No.	Qty Per Art	Air Force		Navy	
			Source Code	Repair Code	Source Code	Repair Code				Source Code	Repair Code	Source Code	Repair Code
AN960C10	9-2-3	6					MS3116F14-5S	9-7-1	1	P1	S	P1	
AN960C10L	9-3-27	1					MS35058-21	9-4-3	2	P1	S	P1	
AN960C6	9-3-7	14	X2	S	P1		MS35058-23	9-4-2	40	P1	S	P1	
AN960C8	9-3-14	2	X2	S	P1		MS35058-29	9-4-12	1	P1	S	P1	
AN960XC10	9-3-3	4	X2	S	P1		MS35059-22	9-4-13	1	P1	S	P1	
AN960XC4	9-4-18	10	X2	S	P1		MS35338-135	9-4-9	8	X2	S	P1	
AN960XC6	9-4-34	3	X2	S	P1		MS35338-135B	9-4-42	6	X2	S	P1	
CARD GATE	9-3-56	1					MS35338-136	9-3-6	11	X2	S	P1	
CHASSIS	9-3-63	1					MS35338-136B	9-4-38	2	X2	S	P1	
CK12BX101K	9-5-44	3	P1	S	P1		MS35338-137	9-4-53	4	X2	S	P1	
CK12BX102K	9-5-55	5	P1	S	P1		MS35649-244	9-4-10	8	X2	S	P1	
CK12BX221K	9-5-66	2	P1	S	P1		MS35650-314	9-6-27	4				
CK12BX222K	9-5-61	2	P1	S	P1		MS51957-14	9-3-20	1	X2	S	P1	
CK12BX471K	9-5-47	4	P1	S	P1		MS51957-15B	9-4-17	4	X2	S	P1	
CK13BX103K	9-5-42	13	P1	S	P1		MS51957-16B	9-4-24	10	X2	S	P1	
CK14BR224K	9-5-58	1					MS51957-17	9-3-35	4	X2	S	P1	
CL65CE271MP3	9-5-64	1					MS51957-19B	9-4-8	4	X2	S	P1	
CM10ED820FP3	9-5-48	2					MS51957-27	9-3-5	11	X2	S	P1	
CM10FD101FP3	9-5-54	3					MS51957-27B	9-4-37	2	X2	S	P1	
CP09A1KC223K3	9-5-59	1	P1	S	P1		MS51957-30	9-3-16	2	X2	S	P1	
D100	9-3-37	16	P1	S	P1		MS51957-31	9-3-49	2	X2	S	P1	
EE2A5GSV	9-5-67	1	P1	S	P1		MS51957-45	9-3-13	7	X2	S	P1	
FM03-1/2A	9-2-6	2	P1	S	P1		MS51957-46B	9-4-33	1	X2	S	P1	
HP-7N	9-3-32	2	X2	S	P1		MS51957-47	9-3-23	1	X2	S	P1	
	9-4-32						MS51958-63B	9-3-2	4	X2	S	P1	
HU6405 1 3/16ST	9-4-21	1	X1	S	X1		MS51958-64	9-2-2	6				
JANIN3611	9-6-14	4	P1	S	P1		M39003/01-2046	9-5-62	2	P1	S	P1	
JANIN746A	9-6-17	1	P1	S	P1		M39003/01-2092	9-5-43	1				
JANIN753A	9-6-3	1					M39003/01-2094	9-5-53	1				
JANIN914	9-5-37	23	P1	S	P1		M39003/01-2178	9-5-57	5	P1	S	P1	
JAN2N2219A	9-5-56	7	P1	S	P1		NAS1635-00-8	9-6-27	4				
JAN2N2222	9-5-38	9	P1	S	P1		NCS6-2-12	9-3-54	1	P1	S	P1	
JAN2N2907A	9-5-49	5	P1	S	P1		NE51H	9-4-15	1				
JA1N040P103UA	9-4-47	7	P1	S	P1		RCR07G100JM	9-5-18	4	P1	S	P1	
JA1N040P504UA	9-4-45	1	P1	S	P1		RCR07G101JM	9-5-7	8	P1	S	P1	
K472FK50J	9-5-52	1					RCR07G102JM	9-5-1	10	P1	S	P1	
LKS832-2	9-3-59	2	X2	S	P1		RCR07G102JS	9-3-46	1	P1	S	P1	
MCR106-1	9-6-1	1	P1	S	P1		RCR07G103JM	9-5-2	25	P1	S	P1	
MC7400P	9-5-39	10	P1	S	P1		RCR07G151JM	9-5-3	1	P1	S	P1	
MC7405P	9-5-51	1	P1	S	P1		RCR07G152JM	9-5-32	2	P1	S	P1	
MC7410P	9-5-45	1	P1	S	P1		RCR07G180JM	9-5-23	1	P1	S	P1	
MC74121P	9-5-46	10	P1	S	P1		RCR07G184JM	9-5-33	1	P1	S	P1	
MC74151P	9-5-63	5	P1	S	P1								
MC7420P	9-5-50	3	P1	S	P1		RCR07G222JM	9-5-14	5	P1	S	P1	
MC7430P	9-5-65	1	P1	S	P1		RCR07G223JM	9-5-25	1	P1	S	P1	
MC7473P	9-5-41	6	P1	S	P1								
MF6001-04	9-4-19	4	X2	S	P1		RCR07G273JM	9-5-5	2				
MF6001-3	9-3-57	4	X2	S	P1		RCR07G274JS	9-3-42	1	P1	S	P1	
MS15795-801	9-6-27E	8					RCR07G332JM	9-5-13	1	P1	S	P1	
MS16535-12	9-6-34	16	X2	S	P1		RCR07G393JM	9-5-11	1				
MS16535-13	9-3-53	5	X2	S	P1		RCR07G393JS	9-3-43	1	P1	S	P1	
MS18034-5NN	9-6-13	10					RCR07G431JM	9-5-21	1	P1	S	P1	
MS20470AD3-3	9-4-20	8	X2	S	P1		RCR07G470JM	9-5-36	1	P1	S	P1	
MS20470AD3-4	9-3-58	8	X2	S	P1		RCR07G471JM	9-5-35	1	P1	S	P1	
MS20470AD4-4	9-3-55	1	X2	S	P1		RCR07G471JS	9-3-47	1	P1	S	P1	
MS21044C04	9-3-21	5	X2	S	P1		RCR07G472JM	9-5-4	9	P1	S	P1	
MS21044C06	9-3-30	3	X2	S	P1		RCR07G5R1JM	9-5-22	1	P1	S	P1	
MS21044C08	9-3-24	3	X2	S	P1		RCR07G561JM	9-6-28	1	P1	S	P1	
MS21266-2N	9-3-62	23 in.					RCR07G622JM	9-5-34	1				
MS3112E14-5P	9-4-23	1	P1	S	P1								

Part Number	Figure and Index No.	Qty Per Art	Air Force		Navy	
			Source Code	Repair Code	Source Code	Repair Code
RCR07G681JM	9-5-28	1				
RCR07G750JM	9-5-17	1	P1	S	P1	
RCR07G751JM	9-6-5	1	P1	S	P1	
RCR07G752JM	9-5-12	1				
RCR07G752JS	9-3-44	1				
RCR07G910JS	9-3-45	1	P1	S	P1	
RCR20G101JM	9-6-22	1	P1	S	P1	
RCR20G151JM	9-6-22	1	P1	S	P1	
RCR20G301JM	9-5-26	1	P1	S	P1	
RCR20G471JS	9-3-41	1	P1	S	P1	
RCR20G512JM	9-5-29	1				
RCR20G622JM	9-6-7	1	P1	S	P1	
RC42GF180J	9-5-24	1	P1	S	P1	
RC42GF332J	9-5-27	1	P1	S	P1	
RC42GF562J	9-6-11	1	P1	S	P1	
RG-62A/U	9-8-3	49 in.	X2	S	MG	
RM52LHA4972-5-62	9-3-18	2	X2	S	P1	
RN55D1692F	9-5-10	1				
RN55D2051F	9-5-9	1	P1	S	P1	
RN55D2742F	9-5-6	2	P1	S	P1	
RN55D5621F	9-5-15	1	P1	S	P1	
RN55D6191F	9-5-19	1	P1	S	P1	
RN55D8252F	9-5-20	1				
RT22C2P103	9-6-27	2				
RT22C2P502	9-5-16	1	P1	S	P1	
RW68V6R8	9-6-19	1				
S-750 -3 L-BB	9-4-49	1	P1	S	P1	
S-775-3	9-4-44	8	P1	S	P1	
SE109D02	9-4-36	2	P1	S	P1	
SE26-1	9-3-22	1	X2	S	NN	
ST310002-7	(SEE HP-7N)					
ST650712-117743	9-8-2	1	M	S	MD	
ST650716-P1	9-7-4	1	M	S	MD	
ST650716-P2	9-7-7	1	M	S	MD	
ST650716-W1	9-7-5	1	M	S	MD	
ST650716-117740	9-7-6	1	M	S	MD	
ST660114-6	(SEE LKS832-2)					
ST850007-2	(SEE 41821)					
ST850064-1	(See 147-4 -032BRASSHT)					
TH0F-3	9-7-8	97 in.	X2	S	P1	
UG-1094A/U	9-4-30	9	P1	S	P1	
UG-260E/U	9-8-1	2	P1	S	P1	
UP131M	9-7-3	1	P1	S	P1	
X1457-2	9-5-71	14	X2	S	NN	
	9-6-31					
10353-A-0832	9-4-51	2	X2	S	MD	
117740	9-2-4	1	A	F	AG	
117743	9-2-5	1	A	F	AG	
121979-1	9-3-4	1	P1	F	P1	
121980-1	9-3-8	1	P1	F	P1	
121984-1	9-2-	1	A	D	P1	
121985-1	9-4-	1	X2	F	X2	
121986-1	9-2-1	1	A	O	AG	
121987-1	9-3-1	1	X1	F	X1	
147-4-032BRASSHT	9-3-19	3	X2	S	P1	
	9-4-11					
	9-4-27					
15-966-2	9-4-5	1				
16-886	9-4-6	1				
16022-A-2	9-4-54	4	X2	S	X2	
1785-2	9-6-30	6	X2	S	NN	

Part Number	Figure and Index No.	Qty Per Art	Air Force		Navy	
			Source Code	Repair Code	Source Code	Repair Code
2JX83	9-4-22	2	P1	S	P1	
2N4852	9-5-40	1	P1	S	P1	
202001-1	9-3-	1	X1	F	X1	
202001P1 thru 202001P8	(NHA 202001-1)					
202003-1	9-3-	1	X2	F	X2	
202003P1	(NHA 202003-1)					
202003P2	(NHA 202003-1)					
250045	(SEE 95-0463-09-21)					
250130-3	(SEE NE51H)					
270557-1	(SEE K472FK50J)					
270626-1	(SEE 39D317F150HS)					
270626-2	(SEE 39D258G015G1)					
270626-3	(SEE 39D128G010HF)					
280060	9-3-25	1	P1	S	P1	
3-582151-4	9-3-40	2	P1	S	P1	
3-582152-9	9-5-70	2	P1	S	P1	
310100-1	(SEE D100)					
330617	(SEE EE2A5GSV)					
331058	(SEE 66009-2)					
331059	(SEE 60599-3)					
331060	(SEE 60804-1)					
341068	(SEE 95-0935)					
341069	(SEE 16022-A-2)					
341070	(SEE 35-1 S2-4-3)					
342015L	9-4-29	1	P1	S	P1	
35-1S2-4-3	9-3-52	2	P1	S	P1	
350573-40	(SEE 3-582151-4)					
350886-5	(SEE 94-62548-33)					
350886-6	(SEE 94-620)					
351628	(SEE 3-58215 9)					
360400	(SEE HU6405 3/16 r)					
360401	(SEE 79W17)					
39D128G010HE4	9-6-25	1	P1	S	P1	
39D258G015GP4	9-6-15	1	P1	S	P1	
39D317F150HS4	9-6-12	2	P1	S	P1	
40372	9-5-60	3	P1	S	P1	
	9-6-10					
40408	9-6-9	1				
410033	(SEE 10353-A 832)					
41821	9-7-2	1	X2	S	NN	
430058	(SEE 342015L)					
522468	9-4-55	1	X1	S	X1	
522469	9-3-12	1	M	S	MG	
522470	9-3-29	1	M	S	MG	
522471	9-5-72	1	X2	S	X2	
522472	9-6-33	4	X1	S	X1	
30599-3	9-6-32	6	X2	S	NN	
30804-1	9-3-39	6	P1	S	P1	
310049	(SEE 907-99)					
320247	(SEE S-775-3)					
320248	(SEE S-750-3L-BB)					
339	9-4-31	6	X2	S	P1	
350820	9-2-7	1				
351705	9-4-1	1	M	S	MD	
36009-2	9-3-38	70	P1	S	P1	
360091-1	(SEE 9556CSS0632-7)					
360091-2	(SEE 9562CSS0632-7)					
360092	(SEE RM52LHA4972-5-62)					
360136-1	(SEE MF6001-04)					

Part Number	Figure and Index No.	Qty Per Art	Air Force		Navy		Part Number	Figure and Index No.	Qty Per Art	Air Force		Navy	
			Source Code	Repair Code	Source Code	Recover Code				Source Code	Repair Code	Source Code	Recover Code
660136-4	(SEE MF6001-						890578	9-3-15	1	P1	S	P1	
670078	9-5-69	5					907-99	9-4-7	1	P1	S	P1	
670099	(SEE 7717-18-N)						911232-1	(SEE MC7400P)					
681106	9-6-35	2					911232-3	(SEE MC7405P)					
690060	(SEE 2JX83)						911232-4	(SEE MC7410P)					
730604	(SEE JA N040		03U				911232-5	(SEE MC7420P)					
730605	(SEE JA N040		04U				911232-6	(SEE MC7430P)					
750371	9-3-50	2	X2	S	MD		911232-7	(SEE MC7473P)					
750376-6-2-12	(SEE N 6-2-						911232-8	(SEE MC74121P)					
761	9-4-46	4	X2	S	P1		911232-9	(SEE MC74151 P)					
	9-4-48						911233	(SEE 40372)					
7717-18-N	9-5-68	13					911234	(SEE 2N4852)					
79W17	9-2-7	1	X2	F	X2		911235	(SEE MCR106)					
810327	9-3-26	1	P1	S	P1		911237	(SEE 4 08)					
8411K12	9-4-4	1	P1	S	P1		94-620	9-3-48	4				
841148-2	9-4-50	1					94-62548-33	9-4-40	1	P1	S	P1	
841149	(SEE 84 K12)						95-0463-09-211	9-4-16	1	P1	S	P1	
850041-01	(SEE X: 07-2)						95-0935	9-4-14	1	P1	S	P1	
850112	(SEE 63						9556CSS0632-7	9-3-60	5	X2	S	NN	
850825	(SEE 17 -2)						9562CSS0632-7	9-3-61	6	X2	S	NN	
850826	(SEE 76						963635	9-3-	1	X2	S	NN	
867036	9-5-74	1	X1	S	X1		963635-01	9-3-	1	X2	S	MG	
867037	9-6-36	1	X1	S	X1		963635-99	9-3-	1	X2	S	MG	

REFERENCE DESIGNATION	FIGURE & INDEX NO	PART NUMBER
A1	9-3-4	121979-1
A1C1	9-5-58	CK14BR224K
A1C2	9-5-42	CK13BX103K
A1C3	9-5-61	CK12BX222K
A1C4	9-5-42	CK13BX103K
A1C5	9-5-57	M39003/01-2178
A1C6 thru A1C8	9-5-55	CK12BX102K
A1C9	9-5-42	CK13BX103K
A1C10	9-5-54	CM10FD101FP3
A1C11	9-5-47	CK12BX471K
A1C12	9-5-57	M39003/01-2178
A1C13	9-5-66	CK12BX221K
A1C14	9-5-42	CK13BX103K
A1C15	9-5-66	CK12BX221K
A1C 16	9-5-62	M39003/01-2046
A1C17	9-5-47	CK12BX471K
A1C18	9-5-62	M39003/01-2046
A1C19	9-5-55	CK12BX102K
A1C20	9-5-61	CK12BX222K
A1C21	9-5-57	M39003/01-2178
A1C22	9-5-42	CK13BX103K
A1C23	9-5-47	CK12BX471K
A1C24	9-5-47	CK12BX471K
A1C25	9-5-42	CK13BX103K
A1C26	9-5-59	CP09A1KC223K3
A1C27	9-5-43	M39003/01-2092
A1C28	9-5-42	CK13BX103K
A1C29	9-5-44	CK12BX101K
A1C30	9-5-48	CM10ED820FP3
A1C31	9-5-44	CK12BX101K
A1C32	9-5-48	CM10ED820FP3
A1C33	9-5-44	CK12BX101K
A1C34	9-5-54	CM10FD101FP3
A1C35	9-5-55	CK12BX102K
A1C36	9-5-57	M39003/01-2178
A1C37	9-5-52	K472FK50J
A1C38	9-5-53	M39003/01-2094
A1C39	9-5-42	CK13BX103K
A1C40	9-5-54	CM10FD101FP3
A1C41	9-5-57	M39003/01-2178
A1C42	9-5-64	CL65CE271MP3
A1C43 thru A1C45	9-5-42	CK13BX103K
A1C46	9-5-42	CK13BX103K
A1CR1 thru A1CR22	9-5-37	JAN1N914
A1Q1	9-5-49	JAN2N2907A
A1Q2	9-5-40	2N4852
A1Q3	9-5-38	JAN2N2222
A1Q4	9-5-49	JAN2N2907A
A1Q5	9-5-56	JAN2N2219A
A1Q6	9-5-38	JAN2N2222
A1Q7	9-5-56	JAN2N2219A
A1Q8	9-5-38	JAN2N2222
A1Q9	9-5-49	JAN2N2907A
A1Q10	9-5-38	JAN2N2222
A1Q11	9-5-49	JAN2N2907A
A1Q12	9-5-56	JAN2N2219A
A1Q13	9-5-60	40372
A1Q14	9-5-56	JAN2N2219A
A1Q15	9-5-38	JAN2N2222
A1Q16	9-5-38	JAN2N2222
A1Q17	9-5-49	JAN2N2907A
A1Q18	9-5-56	JAN2N2219A
A1Q19	9-5-38	JAN2N2222
A1R1	9-5-20	RN55D8252F
A1R2	9-5-3	RCR07G15 1JM
A1R3	9-5-7	RCR07G101JM
A1R4	9-5-36	RCR07G470JM
A1R5	9-5-35	RCR07G471JM
A1R6	9-5-4	RCR07G472JM

REFERENCE DESIGNATION	FIGURE & INDEX NO.	PART NUMBER
A1R7	9-5-4	RCR07G472JM
A1R8	9-5-2	RCR07G103JM
A1R9	9-5-17	RCR07 G7 50JM
A1R10	9-5-4	RCR07G472JM
A1R11	9-5-1	RCR07G102JM
A1R12	9-5-2	RCR07G103JM
A1R13	9-5-14	RCR07G222JM
A1R14	9-5-13	RCR07G332JM
A1R15	9-5-7	RCR07G101JM
A1R16	9-5-1	RCR07G102JM
A1R17	9-5-34	RCR07G622JM
A1R18	9-5-25	RCR07G223JM
A1R19	9-5-19	RN55D6191F
A1R20	9-5-7	RCR07G101JM
A1R21	9-5-2	RCR07G103JM
A1R22	9-5-1	RCR07G102JM
A1R23	9-5-18	RCR07G100JM
A1R24	9-5-2	RCR07G103JM
A1R25	9-5-1	RCR07G102JM
A1R26	9-5-1	RCR07G102JM
A1R27	9-5-28	RCR07G681JM
A1R28	9-5-1	RCR07G102JM
A1R29	9-5-27	RC42GF332J
A1R30	9-5-18	RCR07G100JM
A1R31	9-5-2	RCR07G103JM
A1R32	9-5-7	RCR07G101JM
A1R33	9-5-4	RCR07G472JM
A1R34	9-5-7	RCR07G101JM
A1R35	9-5-29	RCR20G512JM
A1R36	9-5-32	RCR07G152JM
A1R37	9-5-18	RCR07G100JM
A1R38	9-5-2	RCR07G103JM
A1R39	9-5-2	RCR07G103JM
A1R40	9-5-7	RCR07G101JM
A1R41	9-5-2	RCR07G103JM
A1R42	9-5-1	RCR07G102JM
A1R43	9-5-23	RCR07G180JM
A1R44	9-5-24	RC42GF180J
A1R45	9-5-2	RCR07G103JM
A1R46	9-5-14	RCR07G222JM
A1R47	9-5-2	RCR07G103JM
A1R48	9-5-21	RCR07G431JM
A1R49	9-5-33	RCR07G184JM
A1R50	9-5-4	RCR07G472JM
A1R51	9-5-2	RCR07G103JM
A1R52	9-5-2	RCR07G103JM
A1R53	9-5-4	RCR07G472JM
A1R54	9-5-2	RCR07G103JM
A1R55	9-5-2	RCR07G103JM
A1R56	9-5-10	RN55D1692F
A1R57	9-5-9	RN55D2051F
A1R58	9-5-16	RT22C2P502
A1R59	9-5-1	RCR07G102JM
A1R60	9-5-7	RCR07G101JM
A1R61	9-5-1	RCR07G102JM
A1R62	9-5-1	RCR07G102JM
A1R63	9-5-5	RCR07G273JM
A1R64	9-5-4	RCR07G472JM
A1R65	9-5-2	RCR07G103JM
A1R66	9-5-6	RN55D2742F
A1R67	9-5-4	RCR07G472JM
A1R68	9-5-2	RCR07G103JM
A1R69	9-5-6	RN55D2742F
A1R70	9-5-4	RCR07G472JM
A1R71	9-5-2	RCR07G103JM
A1R72	9-5-15	RN55D5621F
A1R73	9-5-7	RCR07G101JM
A1R74	9-5-2	RCR07G103JM
A1R75	9-5-14	RCR07G222JM

REFERENCE DESIGNATION	FIGURE & INDEX NO	PART NUMBER	REFERENCE DESIGNATION	FIGURE & INDEX NO	PART NUMBER
A1R76	9-5-18	RCR07G100JM	A2R2	9-6-29	RCR07G103JM
A1R77 thru A1R80	9-5-2	RCR07G103JM	A2R3	9-6-7	RCR20G622JM
A1R81	9-5-5	RCR07G273JM	A2R4	9-6-5	RCR07G751JM
A1R82	9-5-11	RCR07G393JM	A2R5	9-6-2	RCR07G201JM
A1R83	9-5-12	RCR07G752JM	A2R6	9-6-19	RW68V6R8
A1R84	9-5-2	RCR07G103JM	A2R7	9-6-22	RCR20G101JM
A1R85	9-5-26	RCR20G301JM	A2R8	9-6-11	RC42GF562J
A1R86	9-5-22	RCR07G5R1JM	A2R9	9-6-18	RCR20G151JM
A1R87	9-5-2	RCR07G103JM	A2R10	9-6-28	RCR07G581JM
A1U1	9-5-39	MC7400P	A2R11	9-6-23	RCR07G152JM
A1U2	9-5-39	MC7400P	A2R12	9-6-4	RCR07G222JM
A1U3	9-5-41	MC7473P	A2R13	9-6-4	RCR07G222JM
A1U4	9-5-46	MC74121P	A2R14	9-6-27	RT22C2P103
A1U5	9-5-46	MC74121P	A2R15	9-6-27	RT22C2P103
A1U6 thru A1U8	9-5-39	MC7400P	A2TP1 thru A2TP4	9-6-31	K1457-2
A1U9 thru A1U11	9-5-46	MC74121P	A2VR1	9-6-3	JAN1N753A
A1U12	9-5-50	MC7420P	A2VR2	9-6-17	JAN1N746A
A1U13	9-5-46	MC74121P	DS1	9-4-15	NE51H
A1U14	9-5-46	MC74121P	E1	9-4-36	SE 109D02
A1U15	9-5-41	MC7473P	E2	9-4-36	SE109D02
A1U16	9-5-45	MC7410P	E16	9-3-19	147-4 -032BRASSHT
A1U17	9-5-39	MC7400P	E17	9-3-22	3E26-1
A1U18	9-5-39	MC7400P	F1	9-4-28	FM03-1/2A
A1U19	9-5-41	MC7473P	FL1	9-4-22	2JX83
A1U20	9-5-46	MC74121P	FL2	9-4-22	2JX83
A1U21	9-5-41	MC7473P	J1	9-4-40	34-62548-33
A1U22	9-5-41	MC7473P	J2 thru J10	9-4-30	UG-1094A/U
A1U23	9-5-39	MC7400P	J11	9-4-23	MS3112E14-5P
A1U24	9-5-51	MC7405P	M1	9-4-7	307-99
A1U25	9-5-46	MC74121P	R1	9-4-47	IA1N040P103UA
A1U26	9-5-39	MC7400P	R2	9-4-47	IA1N040P103UA
A1U27	9-5-50	MC7420P	R3	9-3-44	RCR07G752JS
A1U28	9-5-41	MC7473P	R4 thru R6	9-4-47	IA1N040P103UA
A1U29	9-5-50	MC7420P	R7	9-3-47	RCR07G471JS
A1U30	9-5-65	MC7430P	R8	9-3-43	RCR07G393JS
A1U31	9-5-46	MC74121P	R9	9-4-45	IA1N040P504UA
A1U32 thru A1U36	9-5-63	MC74151P	R10	9-3-42	RCR07G274JS
A1U37	9-5-39	MC7400P	R11	9-3-46	RCR07G102JS
A1Y1	9-5-67	EE2A5GSV	R12	9-4-47	IA1N040P103UA
A2	9-3-8	121980-1	R13	9-4-47	IA1N040P103UA
A2C 1	9-6-12	39D317F150HS4	R14	9-3-45	RCR07G910JS
A2C2	9-6-12	39D317F150HS4	R15	9-3-41	RCR20G471JS
A2C3	9-6-15	39D258G015GP4	S1 thru S38	9-4-2	MS35058-23
A2C4	9-6-25	39D128G010HE4	S39	9-4-12	MS35058-29
A2C5	9-6-24	CK13BX103K	S40	9-4-2	MS35058-23
A2CR1	9-6-14	JAN1N3611	S41	9-4-2	MS35058-23
A2CR2	9-6-14	JAN1N3611	S42	9-4-3	MS35058-21
A2CR3	9-6-6	JAN1N914	S43	9-4-4	411K12
A2CR4	9-6-14	JAN1N3611	S44	9-4-3	MS35058-21
A2CR5	9-6-14	JAN1N3611	S45	9-4-50	41148-2
A2E1 thru A2E6	9-6-32	80599-3	S46	9-4-13	MS35059-22
A2Q1	9-6-10	40372	T1	9-3-15	90578
A2Q2	9-6-9	40408	W1	9-2-4	17740
A2Q3	9-6-8	JAN2N2219A	W1 P1	9-7-1	MS3116F14-5S
A2Q4	9-6-10	40372	W1P2	9-7-3	P131M
A2Q5	9-6-8	JAN2N2219A	XA1A	9-3-40	-582151-4
A2Q6	9-6-21	JAN2N2222	XA1B	9-3-40	-582151-4
A2Q7	9-6-21	JAN2N2222	XDS1	9-4-16	5-0463-09-211
A2Q8	9-6-1	MCR106-1	XF 1	9-4-29	42015L

APPENDIX A

REFERENCES

DA Pamphlet 310-4	Index of Technical Manuals, Technical Bulletins, Supply Manuals (Types 7, 8, and 9), Supply Bulletins and Lubrication Orders.
DA Pamphlet 310-7	U. S. Army Equipment Index of Modification Work Orders.
TM 11-6625-366-15	Operator, Organizational, DS, GS and Depot Maintenance Manual for Multimeter TS-352B/U.
TM 11-6625-368-10	Operator's Maintenance Manual for Pulse Generator AN/UPM-15A.
TM 11-6625-700-10	Operator's Maintenance Manual for Electronic Counter AN/USM-207A.
TM 11-6625-1703-15	Operator, Organizational, DS, GS and Depot Maintenance Manual for Oscilloscope AN/USM-281A.
TM 38-750	Army Equipment Record Procedure.
TB SIG 364	Field Instruction for Painting and Preserving Electronic Command Equipment.
TB SIG 355-1	Depot Inspection Standard for Repaired Signal Equipment.
TB SIG 355-2	Depot Inspection Standard for Refinishing Signal Equipment.
TB SIG 355-3	Depot Inspection Standard for Moisture and Fungus Resistant Treatment.

APPENDIX B

MAINTENANCE ALLOCATION

Section I. INTRODUCTION

B-1. GENERAL.

This appendix provides a summary of the maintenance operations for AN/APM-245A. It authorizes categories of maintenance for specific maintenance functions on repairable items and components and the tools and equipment required to perform each function. This appendix may be used as an aid in planning maintenance operations,

B-2. MAINTENANCE FUNCTION.

Maintenance functions will be limited to and defined as follows:

a. **Inspect.** To determine the serviceability of an item by comparing its physical, mechanical, and/or electrical characteristics with established standards through examination,

b. **Test.** To verify serviceability and to detect incipient failure by measuring the mechanical or electrical characteristics of an item and comparing those characteristics with prescribed standards.

c. **Service.** Operations required periodically to keep an item in proper operating condition, i.e., to clean, preserve, drain, paint, or to replenish fuel/lubricants/hydraulic fluids or compressed air supplies.

d. **Adjust.** Maintain within prescribed limits by bringing into proper or exact position, or by setting the operating characteristics to the specified parameters.

e. **Align.** To adjust specified variable elements of an item to bring about optimum or desired performance.

f. **Calibrate.** To determine and cause corrections to be made or to be adjusted on instruments or test measuring and diagnostic equipment used in precision measurement. Consists of the comparison of two instruments, one of which is a certified standard of known accuracy, to detect and adjust any discrepancy in the accuracy of the instrument being compared.

g. **Install.** The act of emplacing, seating, or fixing into position an item, part, module (component or assembly) in a manner to allow the proper functioning of the equipment/system.

h. **Replace.** The act of substituting a serviceable like-type part, subassembly, model (component or assembly) for an unserviceable counterpart.

i. **Repair.** The application of maintenance services (inspect, test, service, adjust, align, calibrate, replace) or other maintenance actions (welding, grinding, riveting, straightening, facing, remachining, or resurfacing) to restore serviceability to an item by correcting specific damage, fault, real function, or failure in a part, subassembly, module/component/assembly, end item or system. This function does not include the trail and error replacement or running spare type items such as fuses, lamps, or electron tubes.

j. **Overhaul.** That periodic maintenance effort (service/action) necessary to restore an item to a completely serviceable/operational condition as prescribed by maintenance standards (e.g., DMWR) in appropriate technical publications. Overhaul is normally the highest degree of maintenance performed by the Army. Overhaul does not normally return an item to like-new condition.

k. **Rebuild.** Consists of those services/actions necessary for the restoration of unserviceable equipment to a like-new condition in accordance with original manufacturing standards. Rebuild is the highest degree of material maintenance applied to Army equipment. The rebuild operation includes the act of returning to zero those age measurements (hours, miles, etc.) considered in classifying Army equipment/components.

B-3. COLUMN ENTRIES.

a. **Column 1, Group Number.** Column 1 lists group numbers, the purpose of which is to identify components, assemblies, subassemblies and modules with the next higher assembly,

b. **Column 2, Component/Assembly.** Column 2 contains the noun names of components, assemblies, subassemblies, and modules for which maintenance is authorized.

c. **Column 3, Maintenance Functions.** Column 3 lists the functions to be performed on the item listed in column 2. When items are listed without maintenance functions, it is solely for purpose of having the group numbers in the MAC and RPSTL coincide.

d. **Column 4, Maintenance Category.** Column 4 specifies, by the listing of a "worktime" figure in the appropriate subcolumn(s), the lowest level of maintenance authorized to perform the function listed in column 3. This figure represents the active time required to perform that maintenance function at the indicated category of maintenance. If the number or complexity of the tasks within

the listed maintenance functions vary at different maintenance categories, appropriate "worktime" figures will be shown for each category. The number of task-hours specified by the "worktime" figure represents the average time required to restore an item (assembly, subassembly, component, module, end item or system) to a serviceable condition under typical field operating conditions. This time includes preparation time, troubleshooting time and quality assurance/quality control time in addition to the time required to perform the specific tasks identified for the maintenance functions authorized in the maintenance allocation chart. Subcolumns of column 4 are as follows:

- C - Operator/Crew
- O - Organizational
- F - Direct Support
- H - General Support**
- D - Depot**

e. Column 5, Tools and Equipment. Column 5 specifies by code, those common tool sets (not individual tools) and special tools, test, and support equipment required to perform the designated functions.

B-4. TOOL AND TEST EQUIPMENT REQUIREMENTS (Table 1).

a. Tool or Test Equipment Reference Code. The numbers in this column coincide with the numbers used in the tools and equipment column of the MAC. The numbers indicate the applicable tool or test equipment for the maintenance functions,

b. Maintenance Category. The codes in this column indicate the maintenance category allocated the tool or test equipment.

c. Nomenclature. This column lists the noun name and nomenclature of the tools and test equipment required to perform the maintenance functions,

d. National/NATO Stock Number. This column lists the National/NATO stock number of the specific tool or test equipment.

e. Tool Number. This column lists the manufacturer's part number of the tool followed by the Federal Supply Code for Manufacturers (5-digit) in parentheses.

**SECTION II. MAINTENANCE ALLOCATION CHART FOR
SIMULATOR TEST SET AN/APM-245A**

(1) GROUP NUM- BER	(2) COMPONENT/ ASSEMBLY	(3) MAINTENANCE FUNCTION	(4) MAINTENANCE CATEGORY					(5) TOOLS AND EQUIPMENT
			C	O	F	H	D	
00	Simulator Test Set AN/APM-245A	Inspect (1)	0.1					
		Test	0.5					1 thru 6
		Service (1)	0.2					7
		Adjust	0.3					1 thru 6
		Align	0.5					1 thru 6
		Install (1)	0.5					7
		Repair	1.0					1 thru 6
		Overhaul	1.5					1 thru 6
01	Cable assemblies	Test	0.2					1
		Repair	0.5					4
		Replace	0.2					

(1) Replace fuses and knobs.

**TABLE 1. TOOL AND TEST EQUIPMENT REQUIREMENTS FOR
SIMULATOR TEST SET AN/APM-245A**

TOOL OR TEST EQUIPMENT REF CODE	MAINTENANCE CATEGORY	NOMENCLATURE	NATIONAL/NATO STOCK NUMBER	TOOL NUMBER
1	H, D	Multimeter AN/USM-223	6625-00-999-7465	
2	H, D	Pulse Generator AN/UPM-15 A	6625-00-682-2581	
3	H, D	Frequency Counter AN/USM-207	6625-00-044-3228	
4	H, D	Tool Kit TK-100/G	5180-00-893-1369	
5	H, D	Oscilloscope AN/USM-281	6625-00-228-2201	
6	H, D	Transistor Test Set TS-1836C/U	6625-00-159-2263	
7	0	Tools and test equipment available to the organizational technician because of assigned mission.		

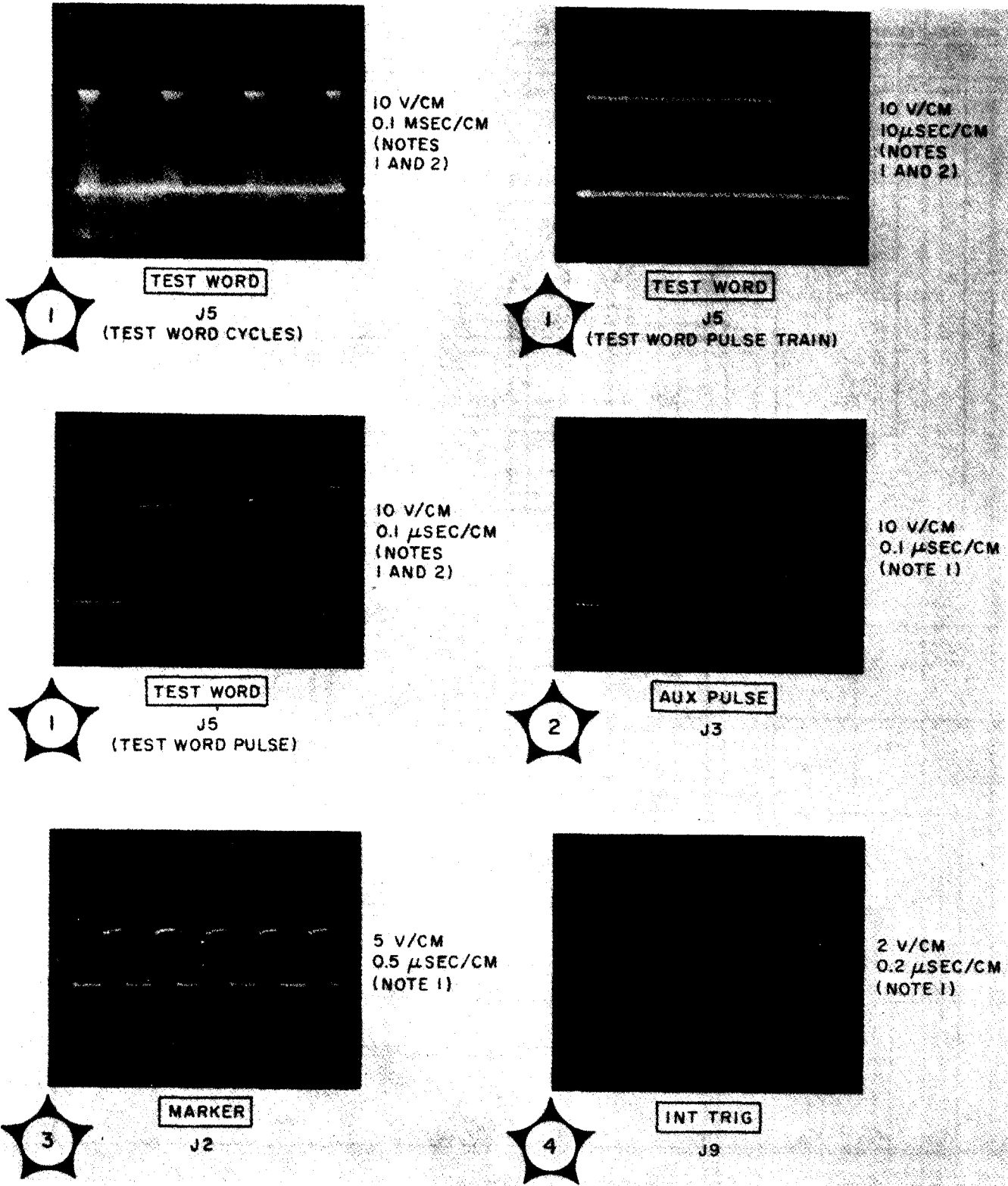

Figure 8-4. Simulator Test Set, Waveforms (Sheet 1 of 3)

ALPHABETICAL INDEX

Subject	Paragraph, Figure, Table, Number
A	
Adjustment	
AUX PULSE AM Control	6 - 9
AUX PULSE DELAY Control	6 - 9
DISPARITY DELAY Control	6-10
INT PRF FREQ ADJ Control	6-7
MARKER AMPLITUDE Control	6-7
MODE 4 REPLY AM Control	6-10
MODE 4 REPLY DELAY Control	6-10
TEST WORD AMPLITUDE Control	6-9
Air Force Source Codes	9-24
Alignment, Power Supply.	6-21
Auxiliary Pulse	
Check	6-9
Depot Tests	7-14
Logic Block Diagram	F4-1
Operating Procedure	4-35
Test Setup	F7-3
Theory Of Operation	4-21
Timing	F4-1
	6-19
chart	
Logic Trouble shooting Flow	F6-1
Maintenance Allocation (Army)	B-2
Checks	
Auxiliary Pulse	6-9
Disparity Pulse	6-10
External Trigger	6-8
Internal Trigger	6-7
Marker Pulses	6-7
Mode 4 Reply	6-10
Operational	6-5
Pre-Operational	3-9
Preventive Maintenance	5-3
Test Word.	6-9
	5-5
Cleaning.	3-7
Connection Precautions, Power	3-7
Connectors	
Function of	T4-2
Location of	F4-3
Controls	
Function of.	T4-1
Location of.	F4-3

ALPHABETICAL INDEX (Cont)

Subject	Paragraph, Figure, Table, Number
D	
Daily Preventive Maintenance	T5-1
Depot Tests	7-1
Disparity Pulse	
Check	6-10
Depot Tests	7-16
Logic Block Diagram	F4-2
Operating Procedure	4-37
Test Setup	F7-4
Theory of Operations	4-26
Thing	F4-2
E	
Electrical Characteristics	1-11
Equipment, Purpose of	1-7
Equipment Supplied	1-13, T1-2
Errors, Reporting of	1-6
External Trigger	
Check	6-8
Depot Tests	7-12
Test Setup	F7-2
F	
Flow Chart, Logic Troubleshooting	F6-1
Forms, Maintenance	1-3
Functions of Test Equipment	T2-1
G	
General Description	1-9
Group Assembly Parts List	9-4
I	
Indicators	
Function of	T4-1
Location of	F4-3
Internal Trigger	
Check	6-7
Depot Tests	7-10
Test Setup	F7-1

ALPHABETICAL INDEX (Cont)

Subject	Paragraph, Figure, Table, Number
L	
Leading Particulars	T1-1
Logic Circuits Assembly AI	
Parts Locations	F9-5
Schematic	F8-1
Logic Diagrams	
Auxiliary Pulse	F4-1
Disparity Pulse	F4-2
Integrated Circuits	F8-3
Marker Pulses	F4-1
Mode 4 Reply	F4-2
Test Word	F4-1
Logic Troubleshooting Flow Chart	F6-1
M	
Maintenance Allocation Chart (Army)	B-2
Manufacturer's Code Symbols	9-12
Marker Pulses	
Check	6-7
Depot Tests	7-10
Logic Block Diagram	F4-1
Operating Procedure	4-38
Test Setup	F7-1
Theory of Operation	4-23
Timing	F4-1
Mechanical Characteristics	1-11
Mode 4 Reply	
Check	6-10
Depot Tests	7-16
Logic Block Diagram	F4-2
Operating Procedure	4-36
Test Setup	F7-4
Theory of Operation	4-24
Timing	F4-2
Monthly Preventive Maintenance	T5-3
N	
Navy Source Codes	9-23
Numerical Index	9-13
O	
Operational Checkout	6-5
P	
Packaging Deficiencies, Reporting of	1-5
Painting, Touch-up	5-7
Parts Locations	
Front Panel	F4-3, T4-1, T4-2
Logic Circuits Assembly AI	F9-5

ALPHABETICAL INDEX (Cont)

Subject	Paragraph, Figure, Table, Number
P (Cont)	
Parts Locations (Cont)	
Power Supply Assembly A2	F9-6
Power Connection Precautions	3-7
Power Supply Alignment	6-21
Power Supply Assembly A2	
Parts Locations	F9-6
Schematic	F8-2
Theory of Operation	4-29
Precautions	
Cleaning Compound	5-5
Power Connection	3-7
Pre-Operational Checks	3-9
Preventive Maintenance	5-3
Provisioning Codes	9-21
Publications, Index of	1-15
Purpose of Equipment	1-7
R	
Records, Maintenance	1-3
Reference Designation Index	9-31
Repair.	6-15
S	
Schematic Diagrams	
Logic Circuits	F8-1
Power Supply Circuits	F8-2
Scope of Manual	1-1
Shipment, Preparation.	3-11
Source Codes	
Air Force	9-24
Navy	9-23
Space Requirements (Setting)	3-5
Starting Procedure	4-33
Stock Numbers	9-19
Stopping Procedure.	4-39
T	
Test Equipment, Functions of	T2-1
Test Word	
Check	6-9
Depot Tests.	7-14
Logic Block Diagram	F4-1
Modes of Operation	4-12
Operating Procedure	4-34
Test Setup	F7-3
Theory of Operation.	4-5
Timing	F4-1

ALPHABETICAL INDEX (Cont)

Subject	Paragraph, Figure, Table, Number
T (Cont)	
Theory of Operation	
Auxiliary Pulse.	4-21
Disparity Pulse.	4-26
General.	4-4
Marker Pulses.	4-23
Mode 4 Reply	4-24
Power Supply Circuits.	4-29
Test Word	4-5
Tool and Test Equipment Requirements (ARMY).	B-3
Troubleshooting	6-13
Troubleshootng Flowchart..	F6-1
u	
Unpacking	3-3
v	
Vendor's Code Symbols	9-12
w	
Waveforms	F8-4
Weekly Preventive Maintenance	T5-2

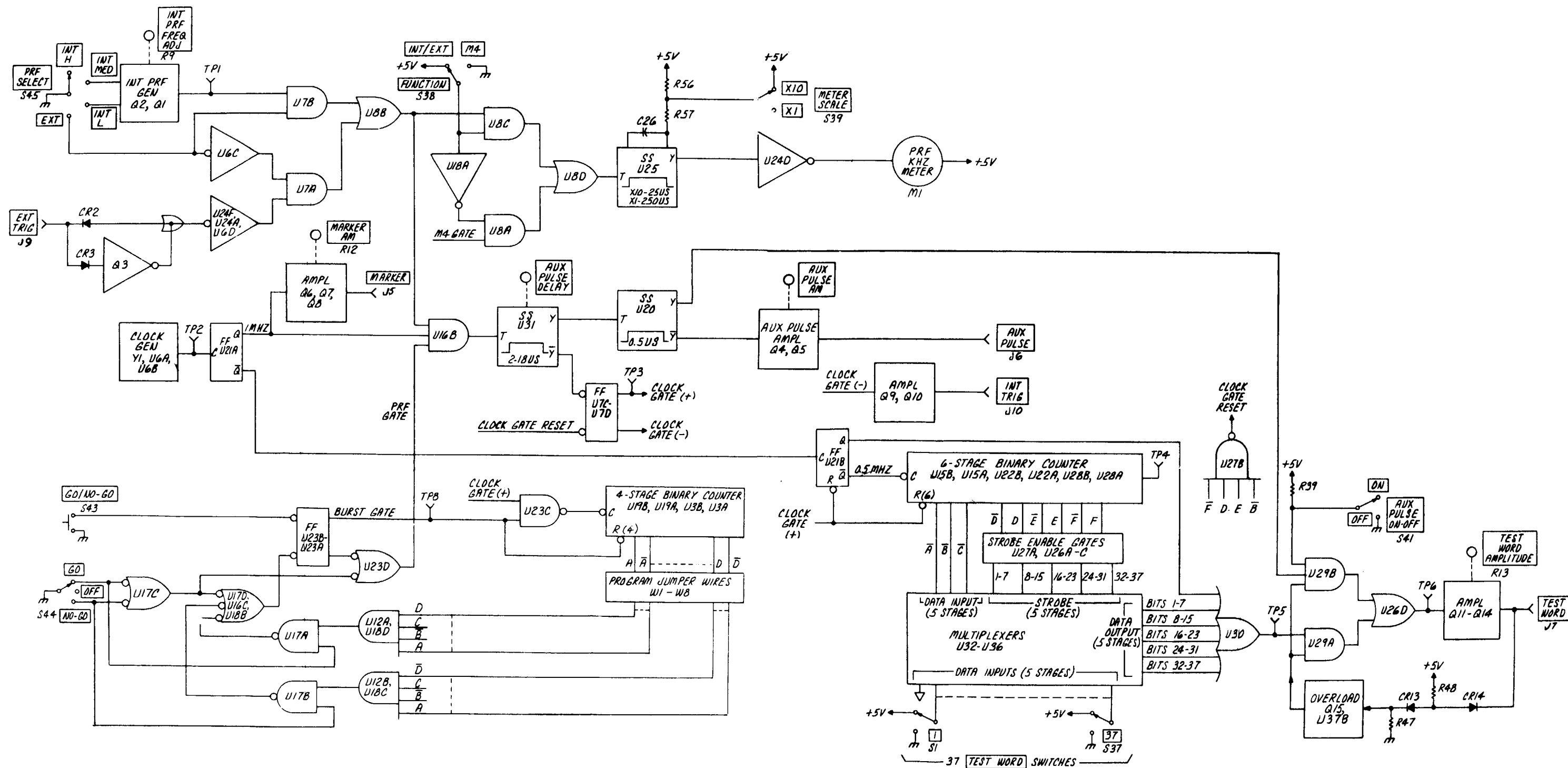
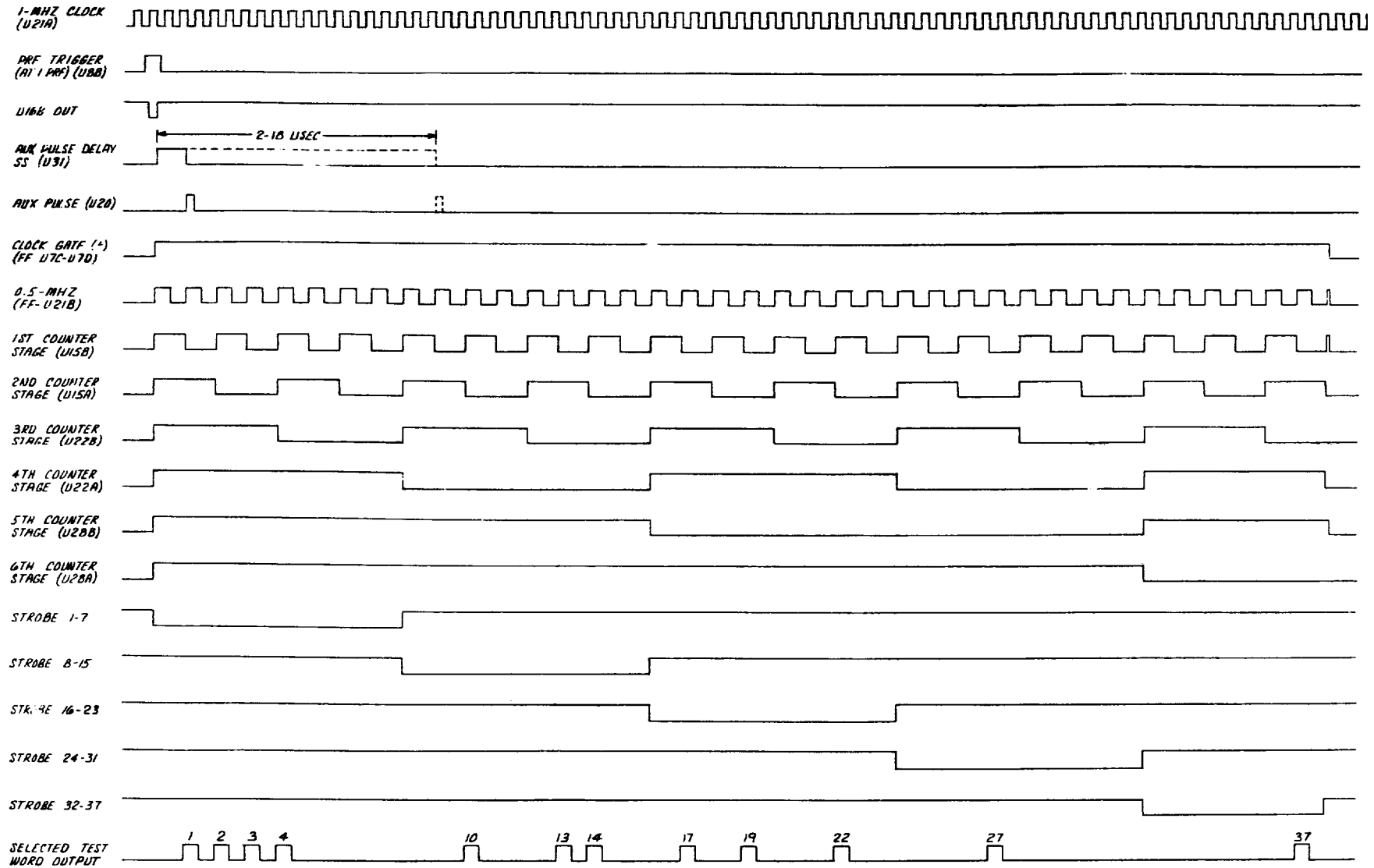

Figure 4-1. Test Word, Auxiliary Pulse, Markers Generator Circuits, Logic Block Diagram (Sheet 1 of 3)



A. TEST WORD GENERATION CYCLE

Figure 4-1. Test Word, Auxiliary Pulse, Markers Generator Circuits, Logic Block Diagram (Sheet 2 of 3)

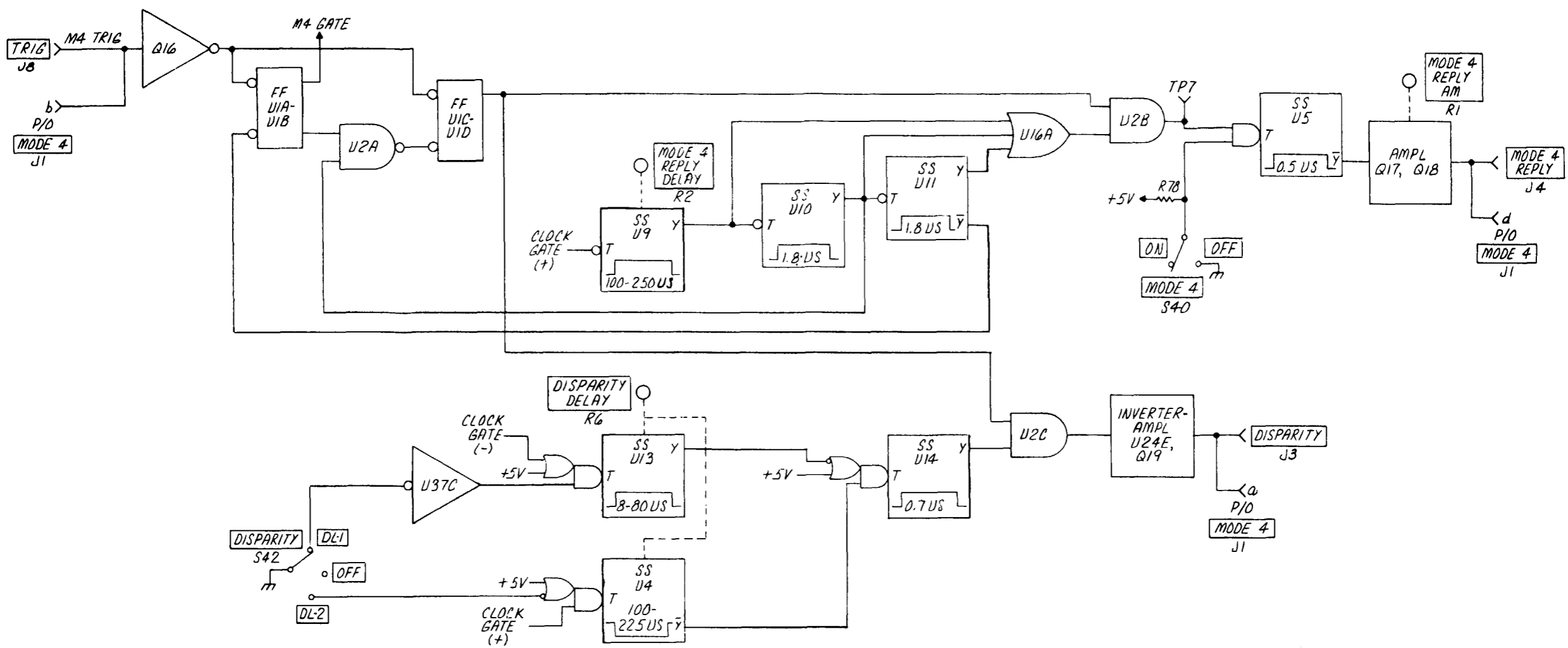

Figure 4-2. Mode 4 Reply and Disparity Pulse Generator Circuits, Logic Block Diagram (Sheet 1 of 2)

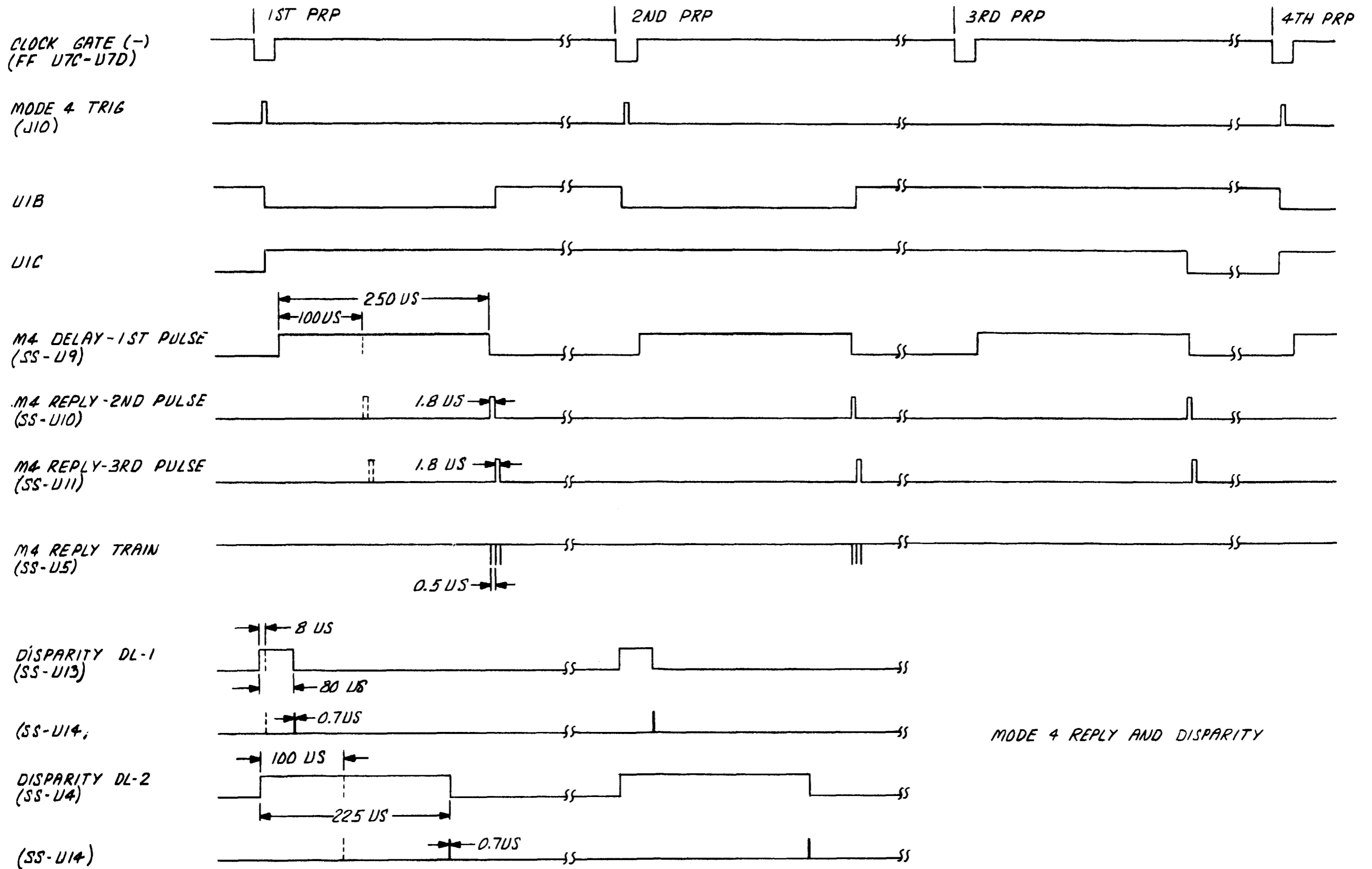

Figure 4-2. Mode 4 Reply and Disparity Pulse Generator Circuits, Logic Block Diagram (Sheet 2 of 2)

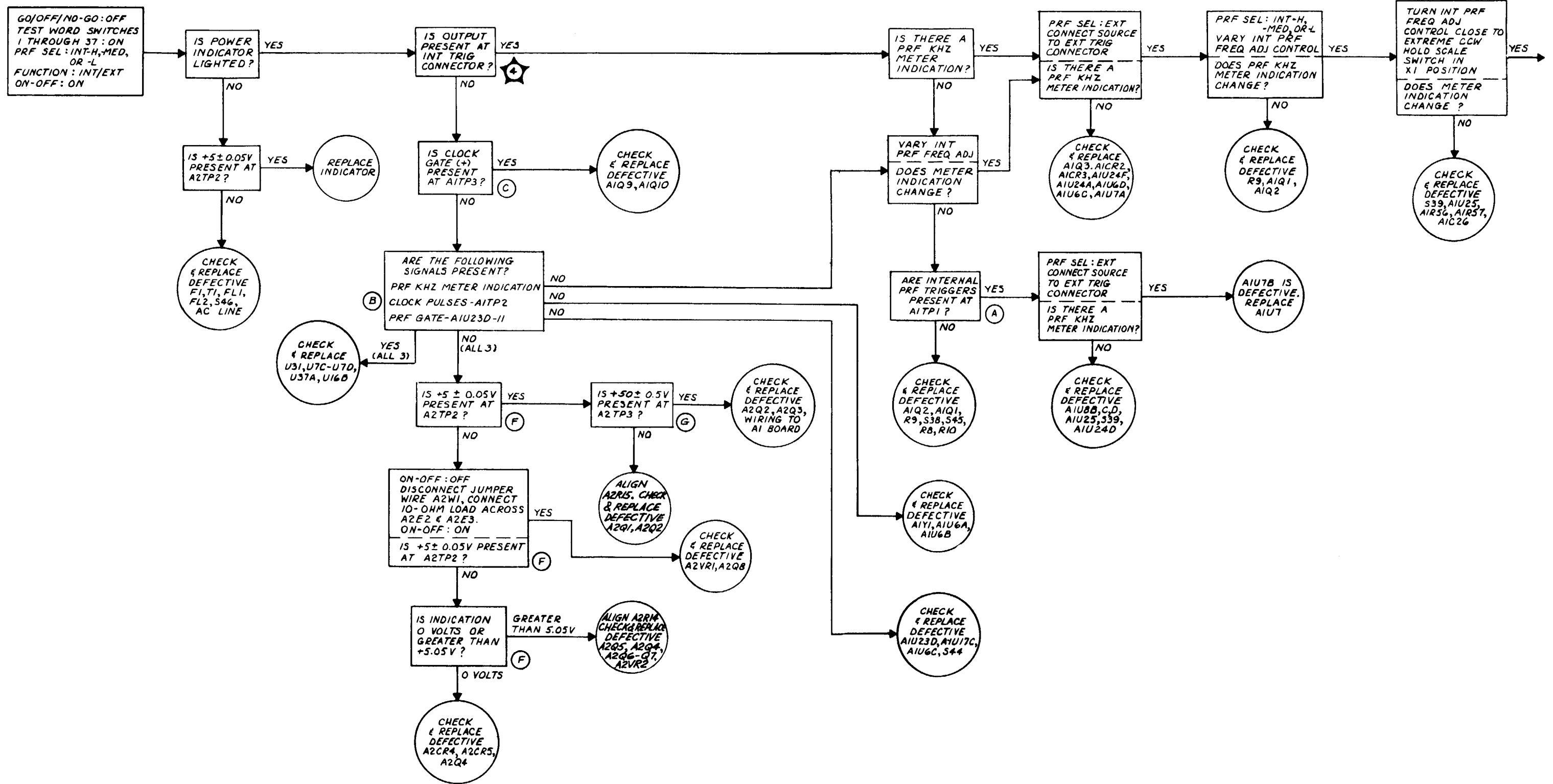

Figure 6-1. Logic Troubleshooting Flow Chart (Sheet 1 of 4)

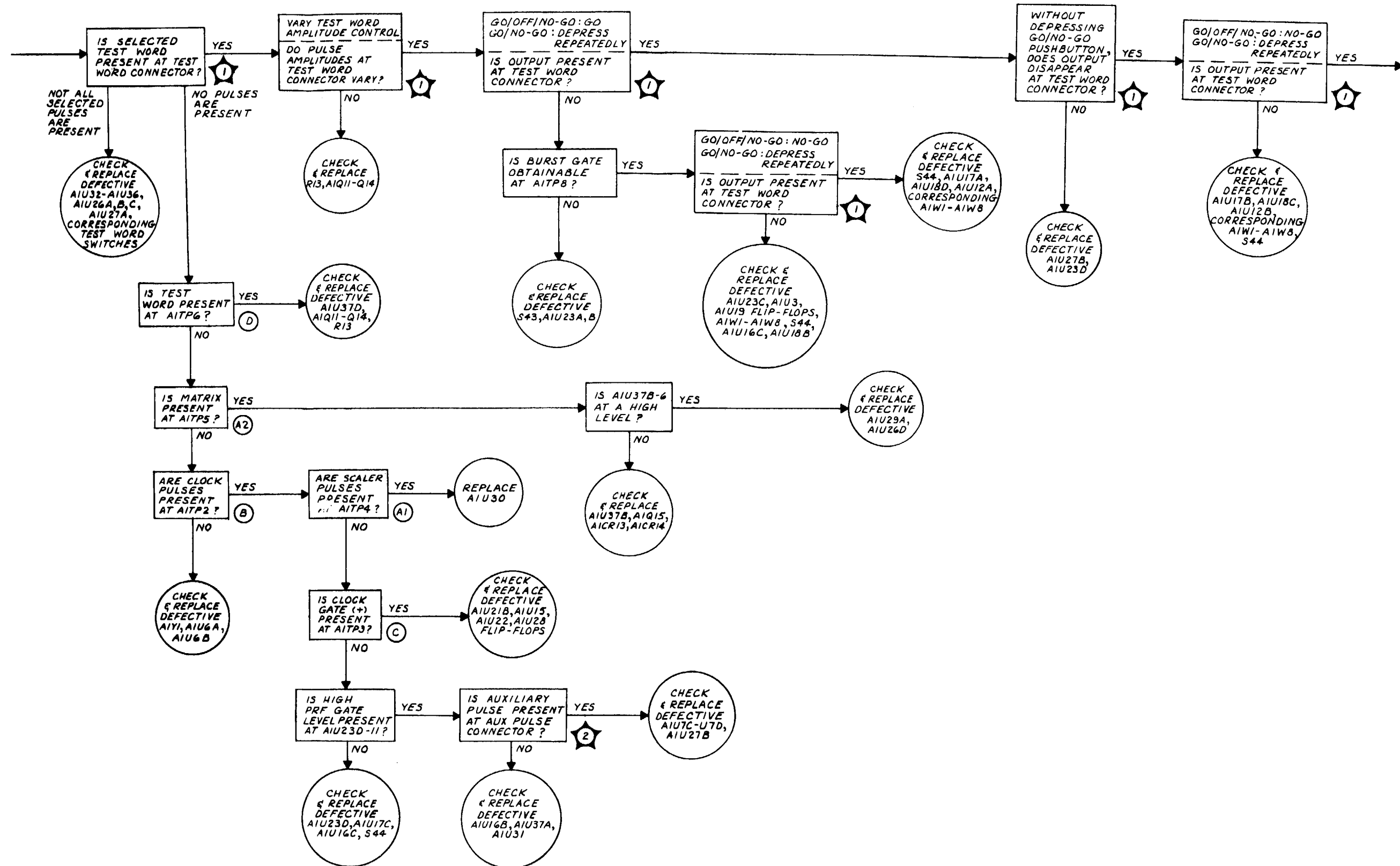

Figure 6-1. Logic Troubleshooting Flow Chart (Sheet 2 of 4)

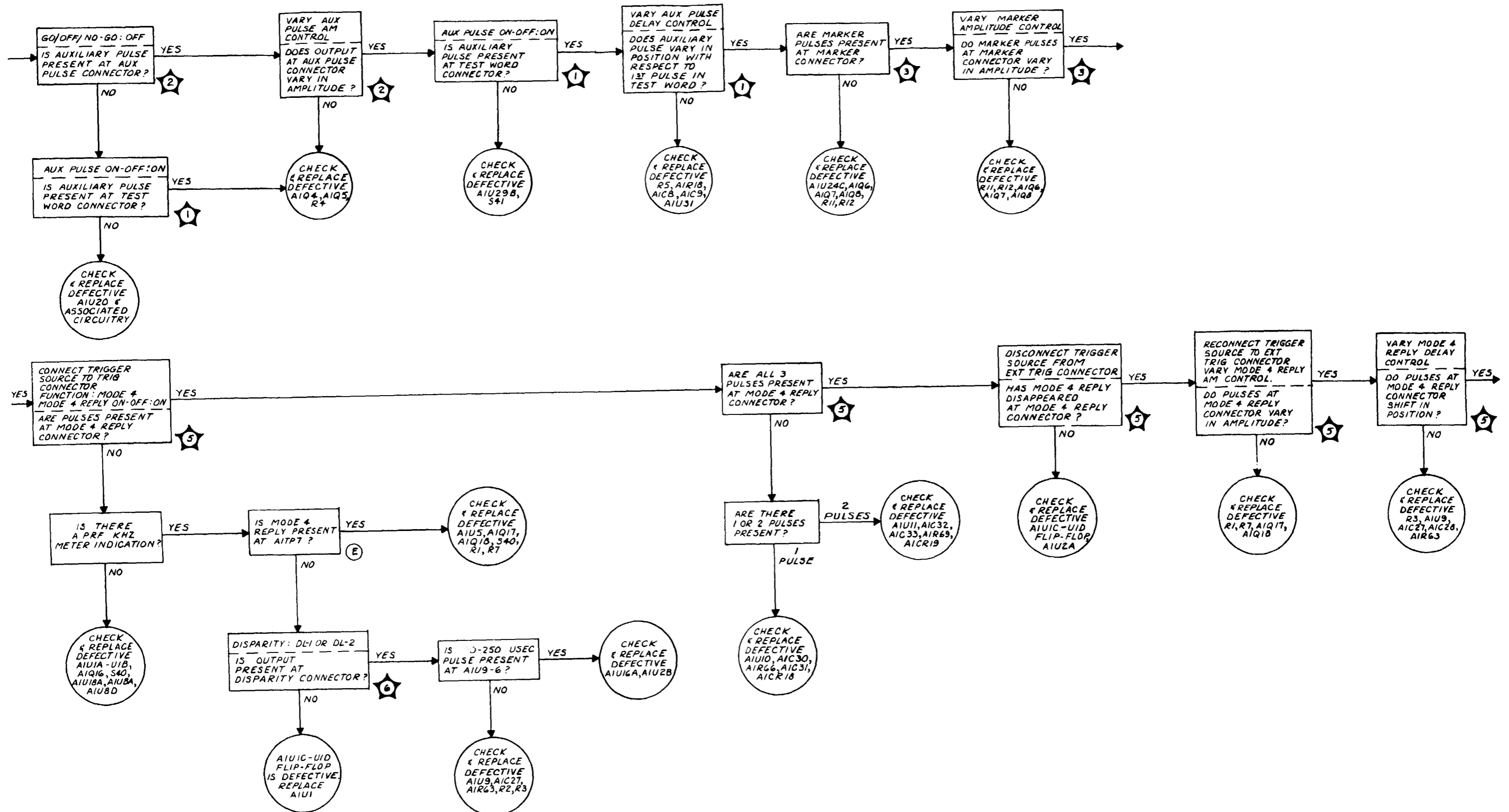

Figure 6-1. Logic Troubleshooting Flow Chart (Sheet 3 of 4)

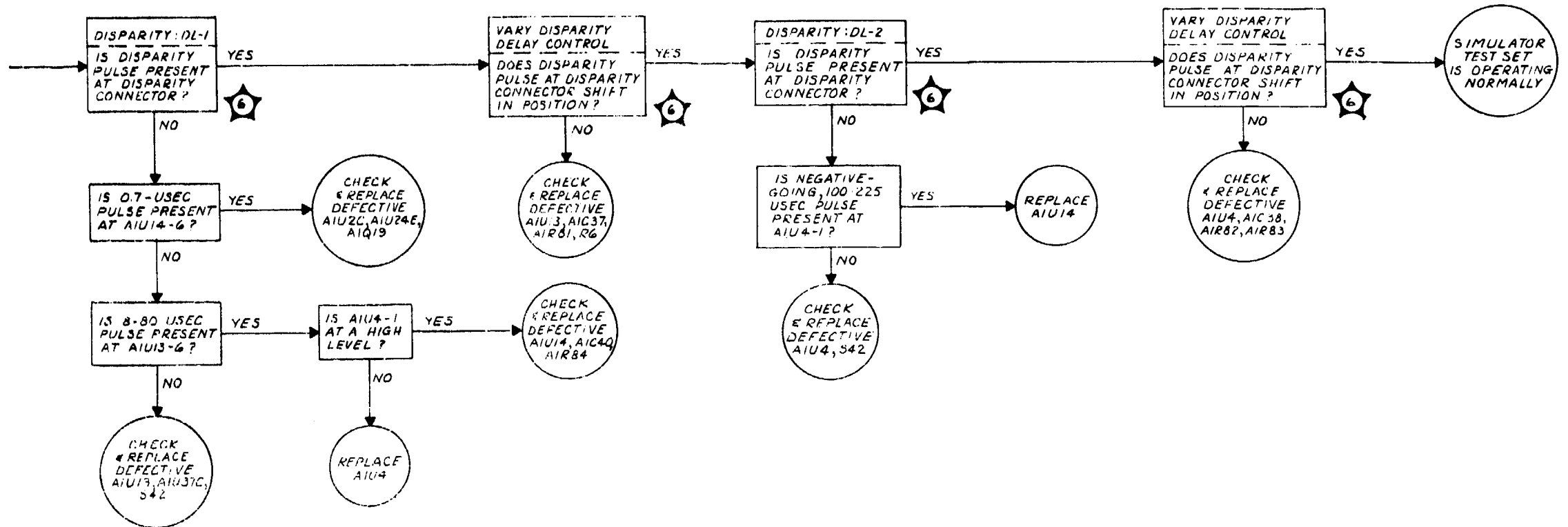

Figure 6-1. Logic Troubleshooting Flow Chart (Sheet 4 of 4)

SECTION VIII

DIAGRAMS

8-1. GENERAL.

8-2. This section contains the equipment schematic diagrams, related waveforms, and equivalent logic representations of the integrated circuits used for the simulator test set. The schematic diagrams for the logic and power supply circuits (figures 8-1 and 8-2, respectively) contain the circuits on the respective printed circuit boards and the associated front panel controls and connectors. In addition, major, secondary, and minor test points are shown, which are keyed to the waveforms shown in figure 8-4 and to specific steps in the logic troubleshooting chart shown in figure 6-1. The major test points are the output signals at the output connectors. The secondary and minor test points are the signals used in respectively isolating trouble to a group of functional circuits and detailed circuits. For reference purposes, a logic representation of the integrated circuits used on the logic board is shown in figure 8-3.

8-3. The index of the diagrams shown in this section is as follows:

<u>FIGURE</u>	<u>TITLE</u>	<u>PAGE</u>
8-1	Simulator Test Set, Logic Circuits, Schematic Diagram (3 sheets)	8-2
8-2	Simulator Test Set, Power Supply Circuits, Schematic Diagram	8-5
8-3	Integrated Circuits, Logic Diagram Equivalent (2 sheets)	8-6
8-4	Simulator Test Set, Waveforms (3 sheets)	8-8

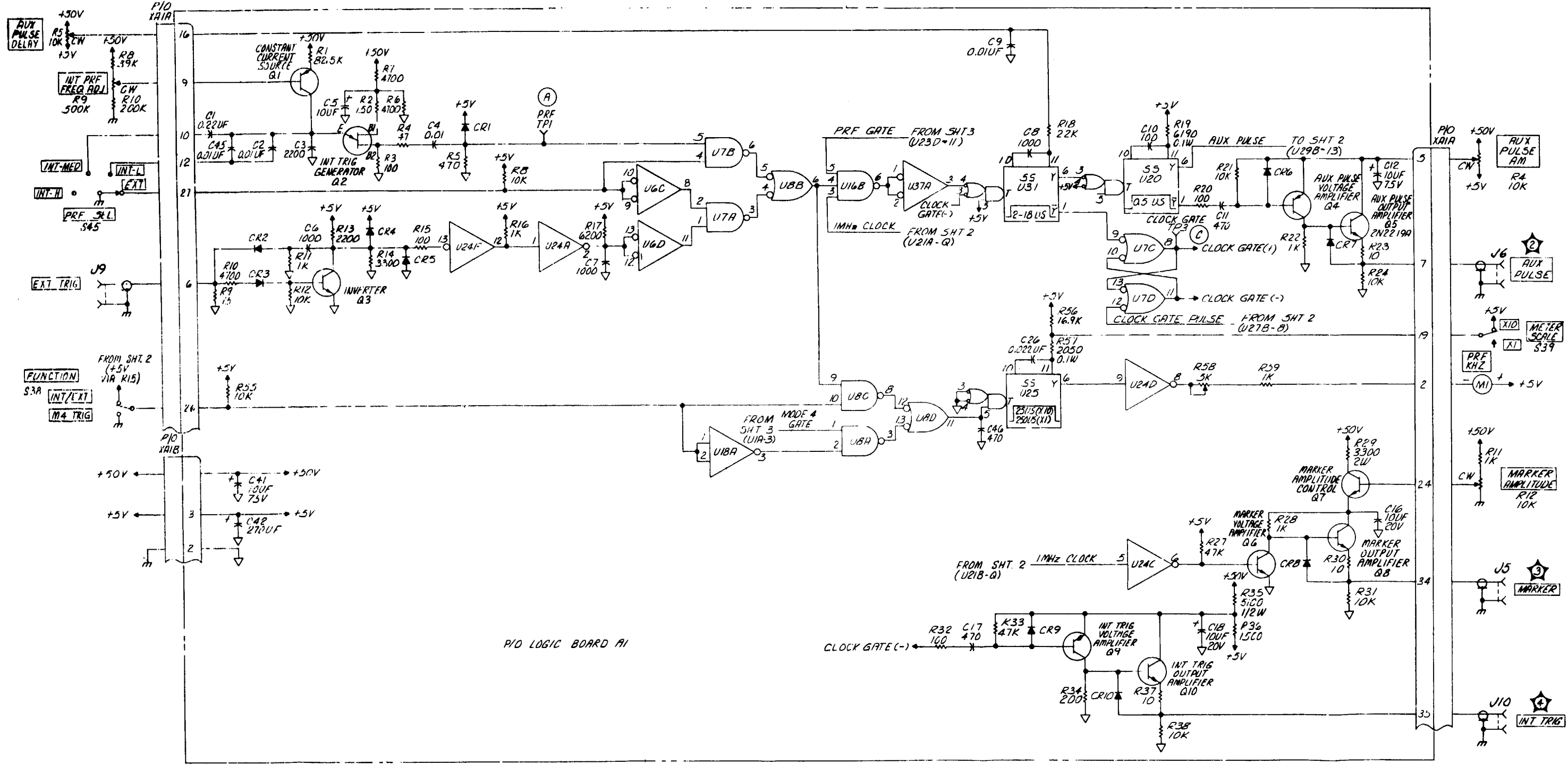

Figure 8-1. Simulator Test Set, Logic Circuits, Schematic Diagram (Sheet 1 of 3)

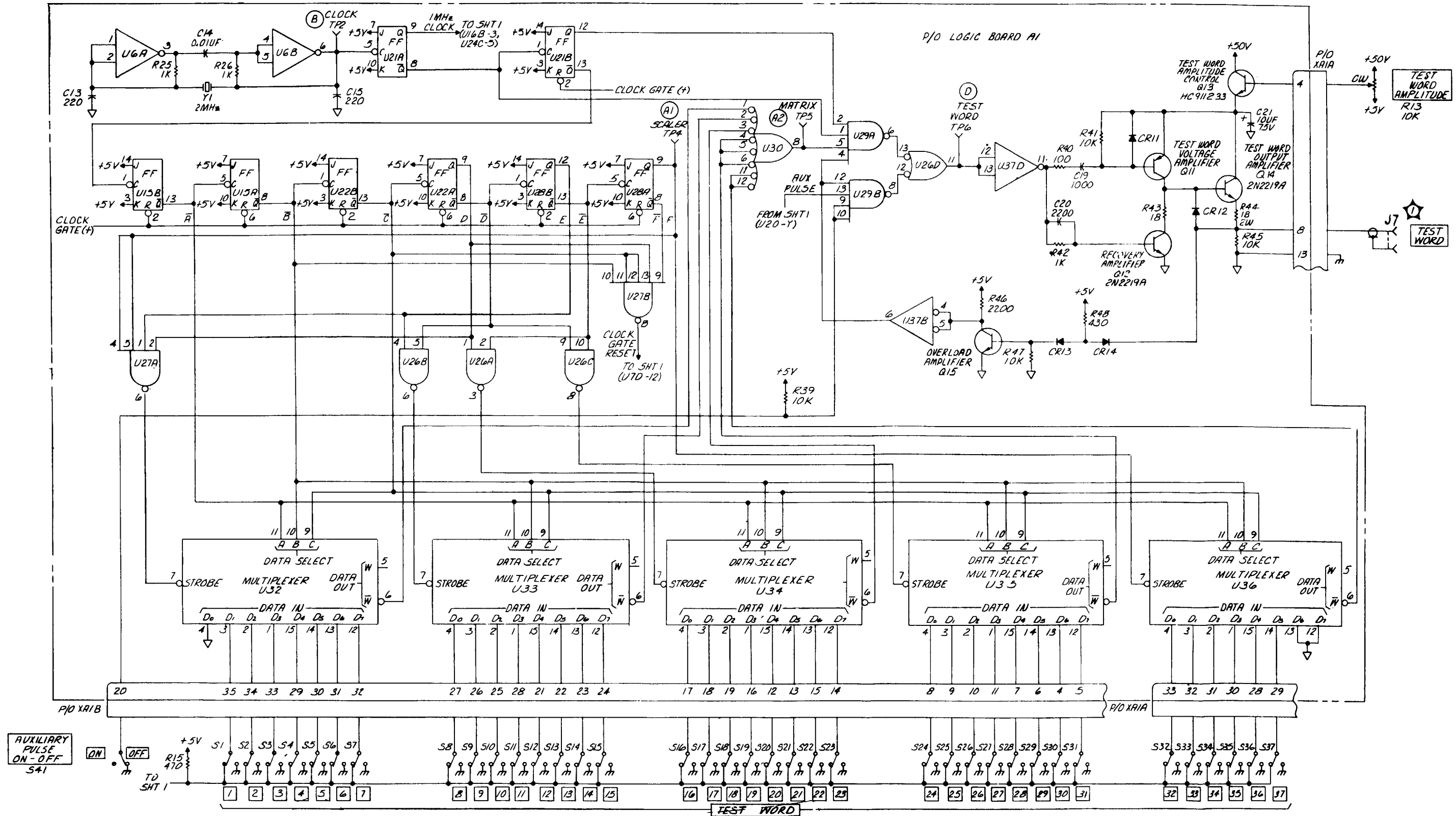
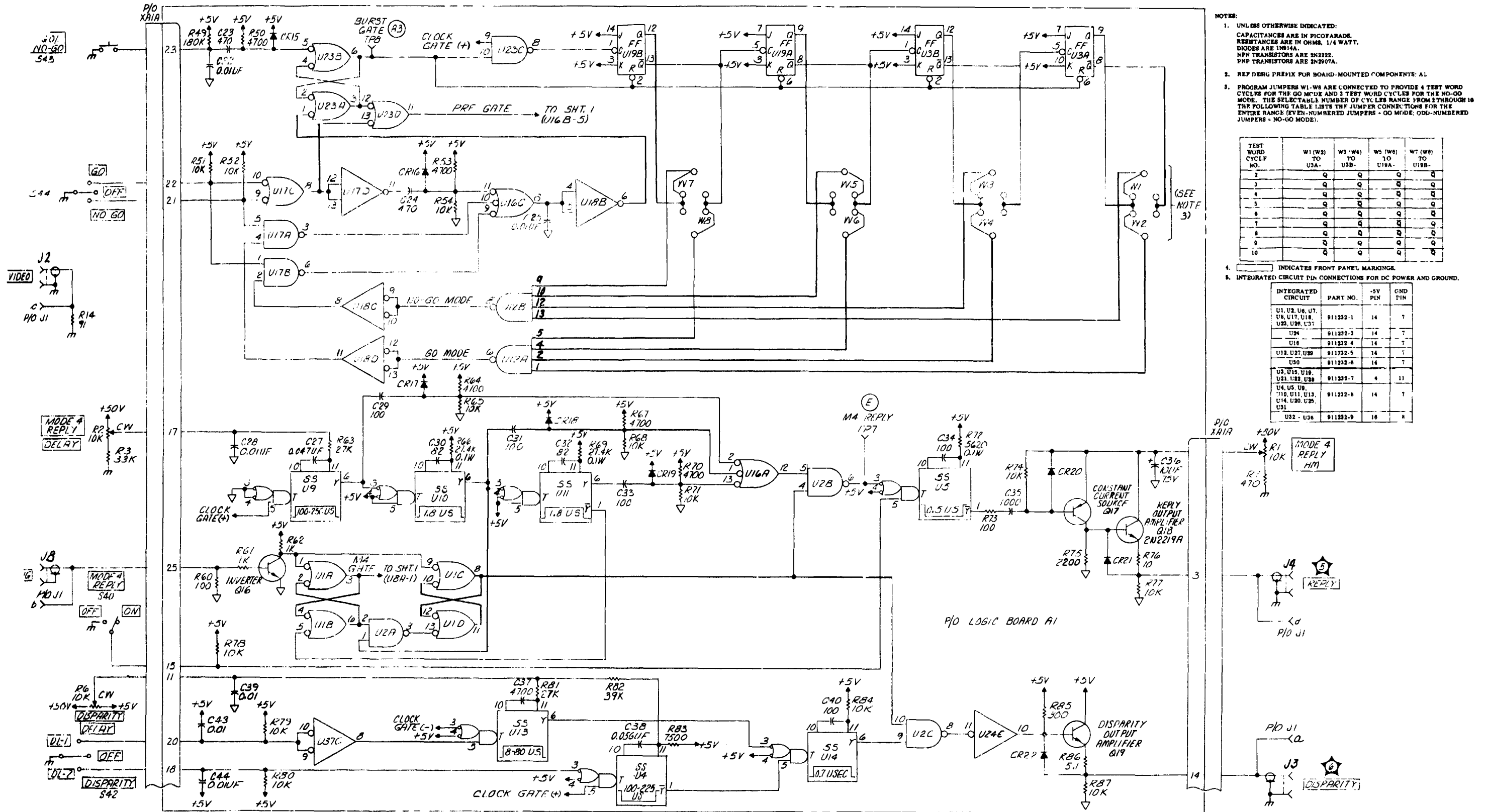

Figure 8-1. Simulator Test Set, Logic Circuits, Schematic Diagram (Sheet 2 of 3)



- NOTES:
- UNLESS OTHERWISE INDICATED: CAPACITANCES ARE IN PICOFARADS. RESISTANCES ARE IN OHMS, 1/4 WATT. DIODES ARE 1N914A. NPN TRANSISTORS ARE 2N2222. PNP TRANSISTORS ARE 2N207A.
 - REF DESIG PREFIX FOR BOARD-MOUNTED COMPONENTS: A1
 - PROGRAM JUMPERS W1-W8 ARE CONNECTED TO PROVIDE 4 TEST WORD CYCLES FOR THE GO MODE AND 3 TEST WORD CYCLES FOR THE NO-GO MODE. THE SELECTABLE NUMBER OF CYCLES RANGE FROM 2 THROUGH 10. THE FOLLOWING TABLE LISTS THE JUMPER CONNECTIONS FOR THE ENTIRE RANGE (EVEN-NUMBERED JUMPERS - GO MODE; ODD-NUMBERED JUMPERS - NO-GO MODE).

TEST WORD CYCLE NO.	W1 (W2) TO USA-	W3 (W4) TO USB-	W5 (W6) TO U19A-	W7 (W8) TO U19B-
2	Q	Q	Q	Q
3	Q	Q	Q	Q
4	Q	Q	Q	Q
5	Q	Q	Q	Q
6	Q	Q	Q	Q
7	Q	Q	Q	Q
8	Q	Q	Q	Q
9	Q	Q	Q	Q
10	Q	Q	Q	Q

- INDICATES FRONT PANEL MARKING.
- INTEGRATED CIRCUIT PIN CONNECTIONS FOR DC POWER AND GROUND.

INTEGRATED CIRCUIT	PART NO.	+5V PIN	GND PIN
U1, U2, U6, U7, U9, U17, U19, U20, U26, U37	911232-1	14	7
U24	911232-3	14	7
U16	911232-4	14	7
U18, U27, U28	911232-5	14	7
U30	911232-6	14	7
U3, U15, U19, U21, U22, U23	911232-7	6	11
U4, U5, U8, U10, U11, U13, U14, U20, U25, U31	911232-8	14	7
U32 - U36	911232-9	16	8

Figure 8-1. Simulator Test Set, Logic Circuits, Schematic Diagram (Sheet 3 of 3)

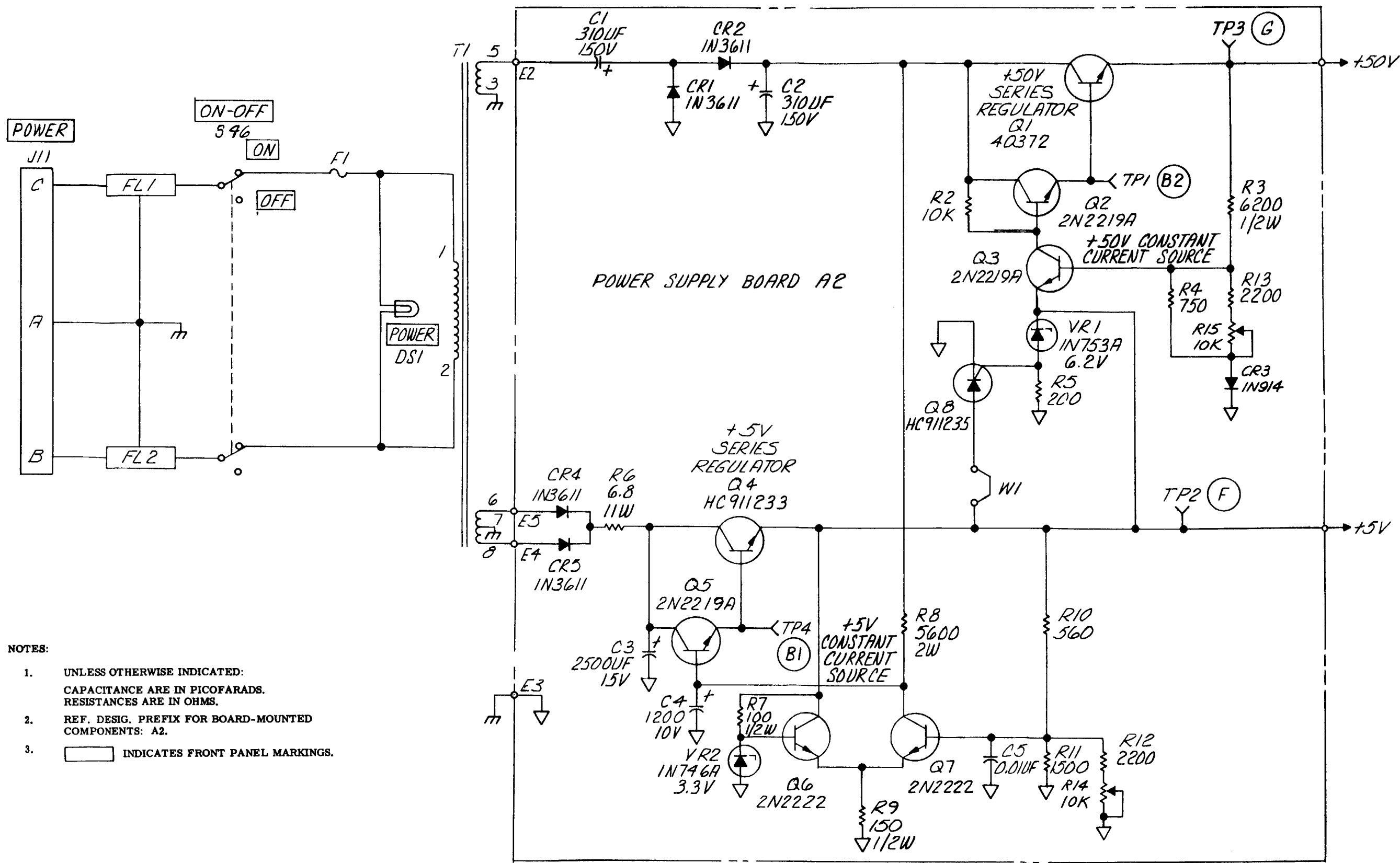

- NOTES:
1. UNLESS OTHERWISE INDICATED:
 CAPACITANCE ARE IN PICOFARADS.
 RESISTANCES ARE IN OHMS.
 2. REF. DESIG. PREFIX FOR BOARD-MOUNTED
 COMPONENTS: A2.
 3. INDICATES FRONT PANEL MARKINGS.

Figure 8-2. Simulator Test Set, Power Supply Circuits, Schematic Diagram

A. QUAD 2-INPUT NAND GATE
 (911232-1)

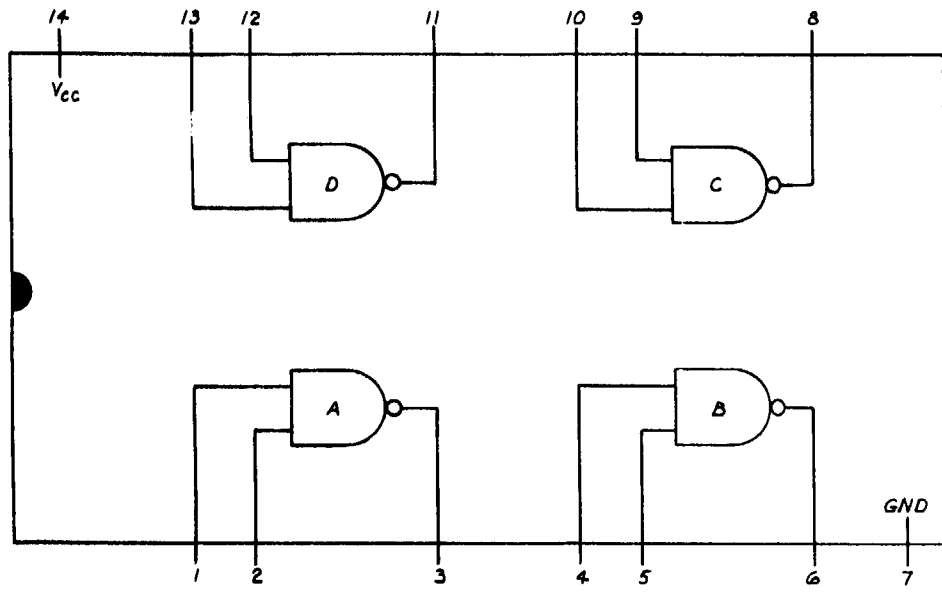

B. HEX INVERTERS
 (911232-3)

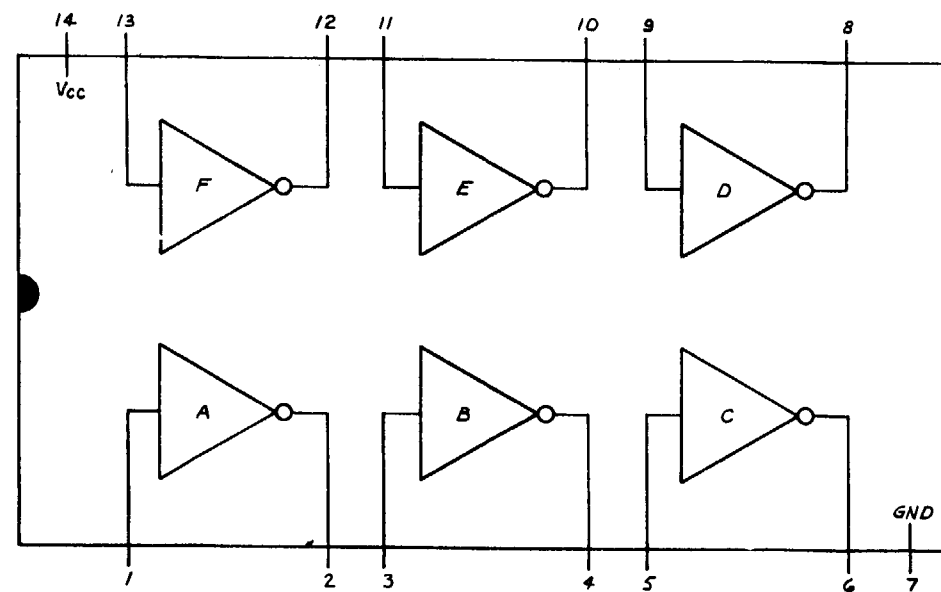

C. TRIPLE 3-INPUT NAND GATE
 (911232-4)

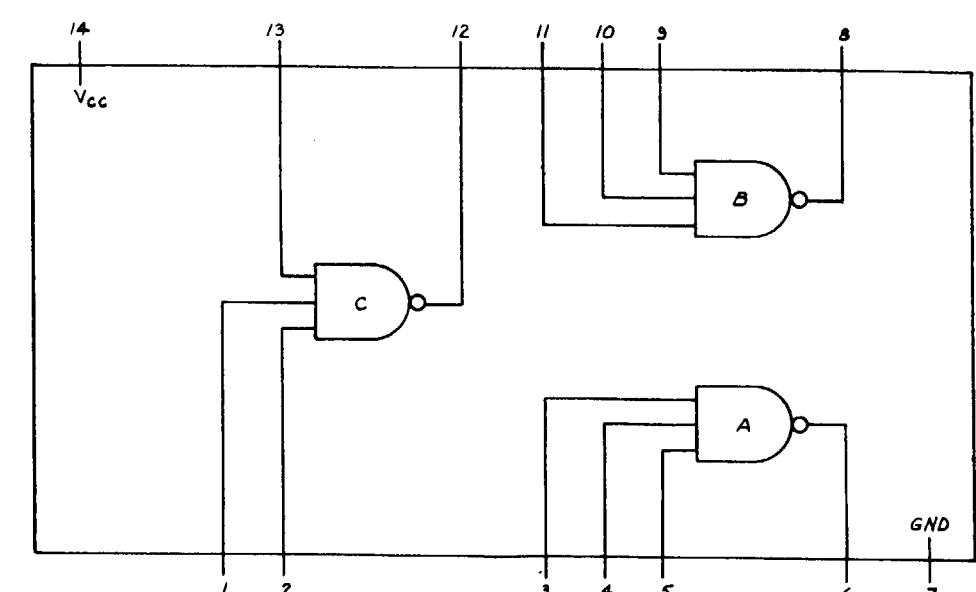

D. DUAL 4-INPUT NAND GATE
 (911232-5)

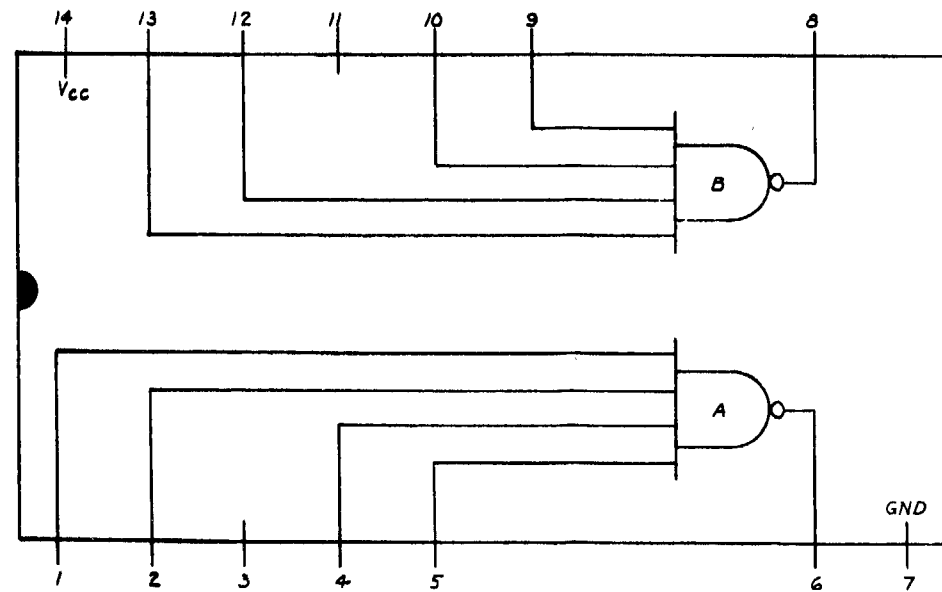

E. 8-INPUT NAND GATE
 (911232-6)

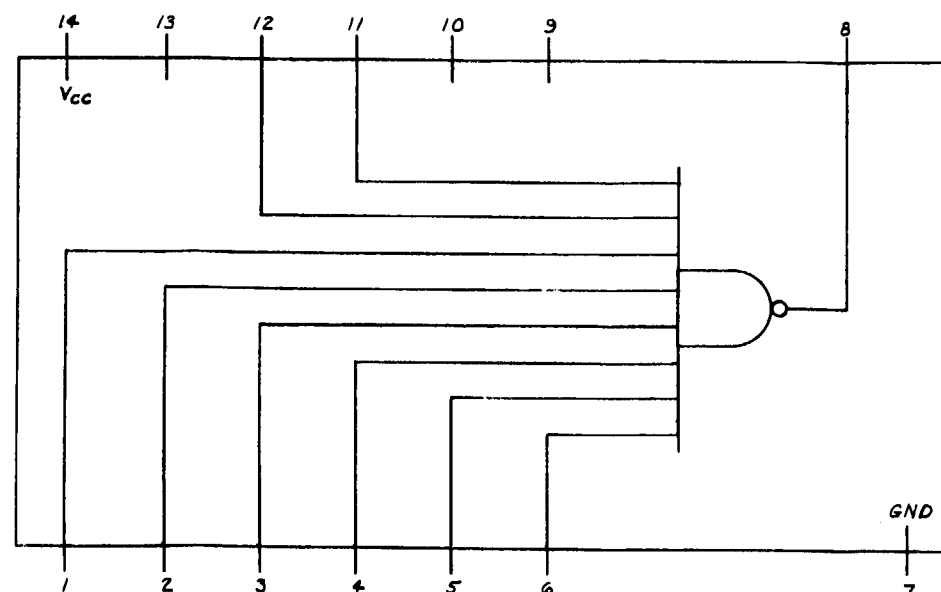

F. DUAL J-K (MASTER-SLAVE) FLIP-FLOP
 (911232-7)

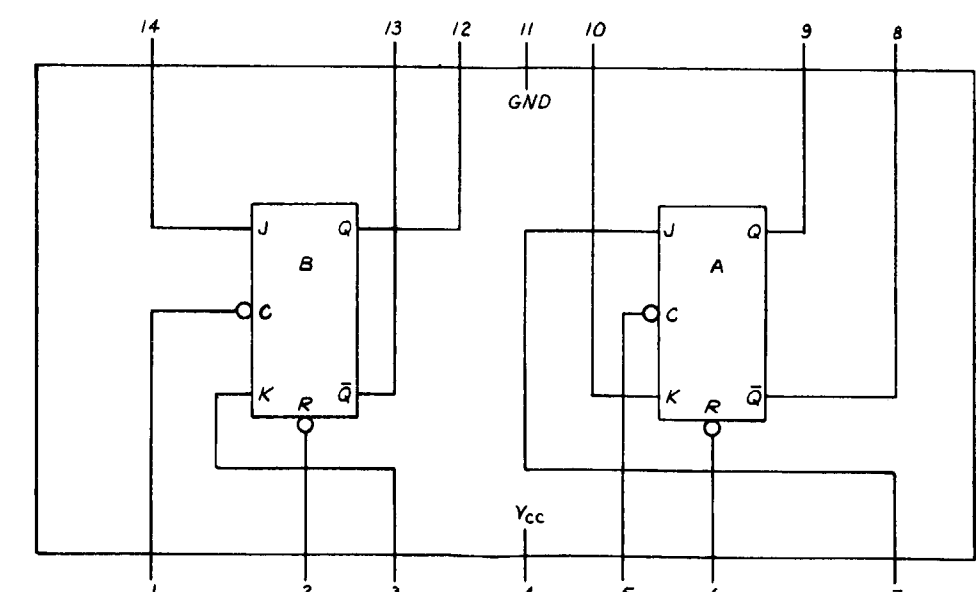

Figure 8-3. Integrated Circuits, Logic Diagram Equivalents (Sheet 1 of 2)

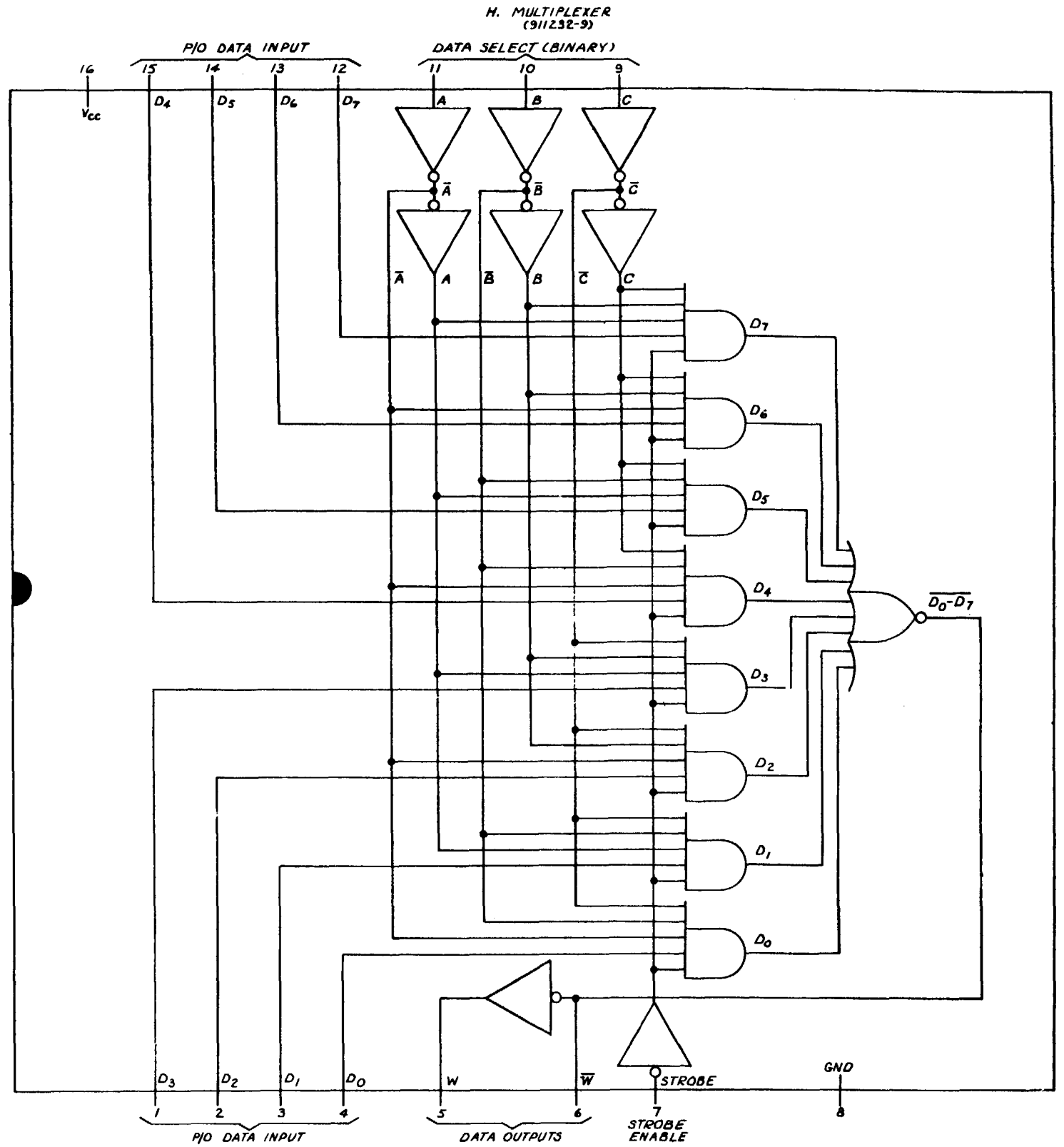
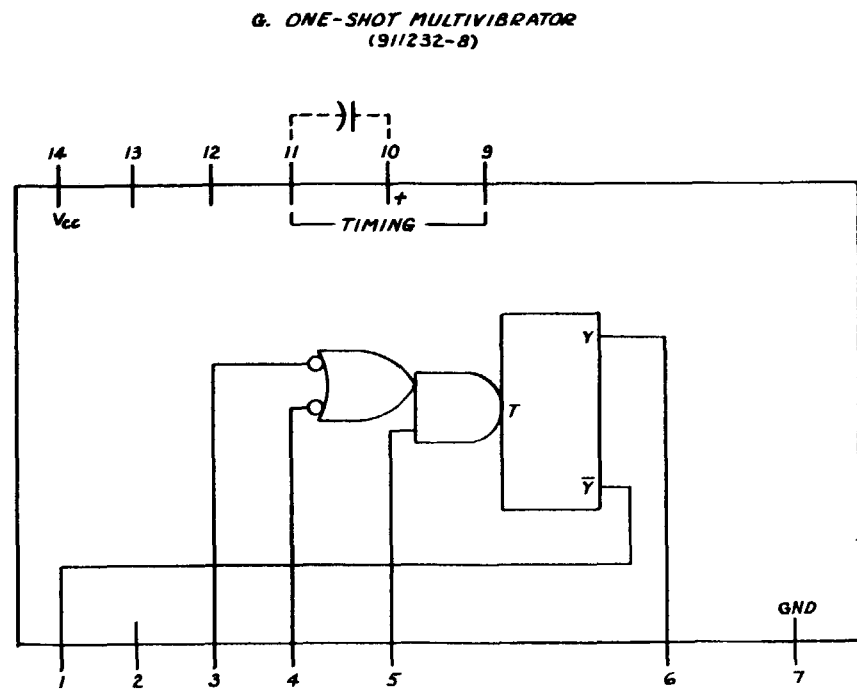

Figure 8-3. Integrated Circuits, Logic Diagram, Equivalents (Sheet 2 of 2)

RECOMMENDED CHANGES TO EQUIPMENT TECHNICAL PUBLICATIONS



THEN...JOT DOWN THE DOPE ABOUT IT ON THIS FORM. CAREFULLY TEAR IT OUT, FOLD IT AND DROP IT IN THE MAIL.

SOMETHING WRONG WITH PUBLICATION

FROM: (PRINT YOUR UNIT'S COMPLETE ADDRESS)

DATE SENT

PUBLICATION NUMBER

PUBLICATION DATE

PUBLICATION TITLE

BE EXACT PIN-POINT WHERE IT IS

PAGE NO.

PARA-GRAPH

FIGURE NO.

TABLE NO.

IN THIS SPACE, TELL WHAT IS WRONG AND WHAT SHOULD BE DONE ABOUT IT.

TEAR ALONG PERFORATED LINE

PRINTED NAME, GRADE OR TITLE AND TELEPHONE NUMBER

SIGN HERE

The Metric System and Equivalents

Linear Measure

1 centimeter = 10 millimeters = .39 inch
 1 decimeter = 10 centimeters = 3.94 inches
 1 meter = 10 decimeters = 39.37 inches
 1 dekameter = 10 meters = 32.8 feet
 1 hectometer = 10 dekameters = 328.08 feet
 1 kilometer = 10 hectometers = 3,280.8 feet

Weights

1 centigram = 10 milligrams = .15 grain
 1 decigram = 10 centigrams = 1.54 grains
 1 gram = 10 decigrams = .035 ounce
 1 dekagram = 10 grams = .35 ounce
 1 hectogram = 10 dekagrams = 3.52 ounces
 1 kilogram = 10 hectograms = 2.2 pounds
 1 quintal = 100 kilograms = 220.46 pounds
 1 metric ton = 10 quintals = 1.1 short tons

Liquid Measure

1 centiliter = 10 milliliters = .34 fl. ounce
 1 deciliter = 10 centiliters = 3.38 fl. ounces
 1 liter = 10 deciliters = 33.81 fl. ounces
 1 dekaliter = 10 liters = 2.64 gallons
 1 hectoliter = 10 dekaliters = 26.42 gallons
 1 kiloliter = 10 hectoliters = 264.18 gallons

Square Measure

1 sq. centimeter = 100 sq. millimeters = .155 sq. inch
 1 sq. decimeter = 100 sq. centimeters = 15.5 sq. inches
 1 sq. meter (centare) = 100 sq. decimeters = 10.76 sq. feet
 1 sq. dekameter (are) = 100 sq. meters = 1,076.4 sq. feet
 1 sq. hectometer (hectare) = 100 sq. dekameters = 2.47 acres
 1 sq. kilometer = 100 sq. hectometers = .386 sq. mile

Cubic Measure

1 cu. centimeter = 1000 cu. millimeters = .06 cu. inch
 1 cu. decimeter = 1000 cu. centimeters = 61.02 cu. inches
 1 cu. meter = 1000 cu. decimeters = 35.31 cu. feet

Approximate Conversion Factors

To change	To	Multiply by	To change	To	Multiply by
inches	centimeters	2.540	ounce-inches	newton-meters	.007062
feet	meters	.305	centimeters	inches	.394
yards	meters	.914	meters	feet	3.280
miles	kilometers	1.609	meters	yards	1.094
square inches	square centimeters	6.451	kilometers	miles	.621
square feet	square meters	.093	square centimeters	square inches	.155
square yards	square meters	.836	square meters	square feet	10.764
square miles	square kilometers	2.590	square meters	square yards	1.196
acres	square hectometers	.405	square kilometers	square miles	.386
cubic feet	cubic meters	.028	square hectometers	acres	2.471
cubic yards	cubic meters	.765	cubic meters	cubic feet	35.315
fluid ounces	milliliters	29.573	cubic meters	cubic yards	1.308
pints	liters	.473	milliliters	fluid ounces	.034
quarts	liters	.946	liters	pints	2.113
gallons	liters	3.785	liters	quarts	1.057
ounces	grams	28.349	liters	gallons	.264
pounds	kilograms	.454	grams	ounces	.035
short tons	metric tons	.907	kilograms	pounds	2.205
pound-feet	newton-meters	1.356	metric tons	short tons	1.102
pound-inches	newton-meters	.11296			

Temperature (Exact)

°F Fahrenheit temperature 5/9 (after subtracting 32) Celsius temperature °C

PIN: 017474-003